

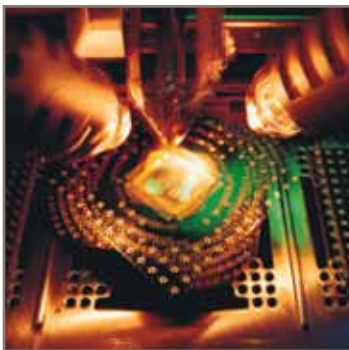

aerospace
climate control
electromechanical
filtration
fluid & gas handling
hydraulics
pneumatics
process control
sealing & shielding

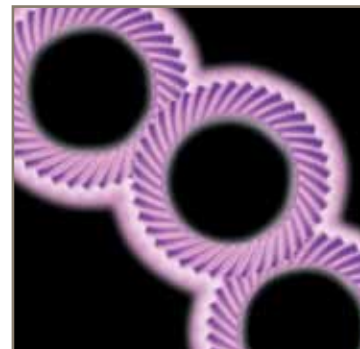

Gearheads and Gearmotors



ENGINEERING YOUR SUCCESS.

Parker Hannifin Corporation

A Fortune 300 company with annual sales exceeding \$10 billion and more than 400,000 customers in 43 countries, Parker Hannifin is the world's leading supplier of innovative motion control components and system solutions serving the industrial, mobile, and aerospace markets. We are the only manufacturer offering customers a choice of electromechanical, hydraulic, pneumatic, or computer-controlled motion systems.

Total System Solutions

Parker's team of highly qualified application engineers, product development engineers, and system specialists can turn pneumatic, structural, and electromechanical products into an integrated system solution.

Moreover, our Selectable Levels of Integration™ allows you to choose the appropriate system, subsystem, or component to meet your specific need.



Parker offers complete engineered systems.

First in Delivery, Distribution, and Support

In today's competitive, fast-moving economy, what good is an application that isn't ready on time? This is especially true when compressed design cycles make the quick delivery of critical components essential. With factories strategically located on five continents, Parker offers an unrivaled delivery record, getting solutions out our door and onto your floor faster than ever.

Parker also has the industry's largest global distribution network, with more than 8,600 distributors worldwide. Each of these locations maintains ample product inventory to keep your downtime to a minimum. And many distributors have in-house design capabilities to support your system and subsystem requirements.

Throughout the design process, Parker's factory-trained electromechanical engineers work hand in hand with you and day or night at 1-800-C-Parker. Our operators will connect you with a live, on-call representative who will identify replacement parts or services for all motion technologies.



Parker world headquarters in Cleveland

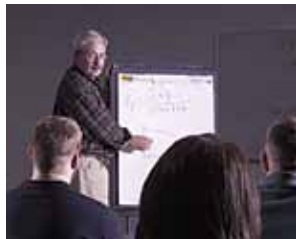

Training

Parker's best-in-class technology training includes hands-on classes, Web-based instruction, and comprehensive texts for employees, distributors,

and customers. Parker also provides computer-based training, PowerPoint presentations, exams, drafting and simulation software, and trainer stands.

parkermotion.com

Our award-winning Web site is your single source for:

- **Product information**
- **Downloadable catalogs**
- **Motion-sizing software**
- **3D design files**
- **Training materials**
- **Product-configuration software**
- **RFQ capabilities**
- **Videos and application stories**



24/7 Emergency Breakdown Support

The Parker product information center is available any time of the day or night at 1-800-C-Parker. Our operators will connect you with a live, on-call representative who will identify replacement parts or services for all motion technologies.



Table of Contents

Product Overview

4 – 7 Products and Technologies; Application Examples

Planetary Gearheads

8 – 49 Overview and Selection

Generation II Stealth® PS/PX/RS/RX Series:

- 60 – 115 mm / NEMA 23-42
- In-line and Right Angle

Generation I Stealth® PS/PX/RS/RX Series:

- 142 – 220 mm / NEMA 56
- In-line and Right Angle

PV Series:

- 40 – 115 mm / NEMA 17-42
- In-line

Multi-Drive Right-Angle Gearheads

50 – 57 Overview and Selection

- **RT Hollow Shaft Series:** 90 – 220 mm
- **RD Double Shaft Series:** 90 – 220 mm
- **RB Low Ratio Series:** 90 – 220 mm

Bevel/Spur Gearheads

58 – 61 Overview and Selection

- **NE Series:** NEMA 23 – 42 (In-line)

Gearmotors (integrated planetary gearhead and servo motor)

62 – 68 Overview and Selection

DX Series ServoWheel™:

- Gearmotor Drive Wheels for Electric Vehicles

Related Products and Services

69 – 71 Other Parker Products

72 – 73 Gearhead Sizing/Selection Design Reference

74 Offer of Sale

If you don't find exactly what you are looking for in this catalog, please contact us for information on other suitable Parker products or to have an application engineer discuss your requirements.

Visit our Website

Complete up-to-date technical assistance can be found on our web at www.parkermotion.com. This includes all the latest information on current products, new product introductions, local assistance and support, plus a comprehensive “Engineering Reference Library” including: complete product catalog data, product selection Wizards, performance charts and graphs, engineering data and calculations, CAD drawings, local service and support directory, on-line purchasing, application stories and videos.



Welcome!

Thank you for your interest in the products offered by the Parker Hannifin Electromechanical Automation Division. This catalog presents Parker's electromechanical solutions for high-precision and high-speed automation. Our gearheads, motors, and integrated products are recognized around the world for their functionality, performance, and reliability.

Bayside pioneered the market for precision servo gearheads many years ago. Parker continues this tradition in quality and design with innovations like our Stealth Generation II Helical Planetary Gearhead, enhanced to provide superior performance for the most demanding applications. Our PV Series planetary gearhead combines power and versatility in an economical package. Our line of Frameless Motors, Servo Wheels, and other integrated products provide an ideal solution for machine designs that require high performance in small spaces.

As you read through this catalog, you will discover that Parker offers the widest variety of electromechanical solutions that are delivered in the shortest amount of time. Still, many customers require special solutions to satisfy unique or special requirements. Parker has been providing custom engineered solutions for over 30 years to satisfy those requirements. If your application cannot be fulfilled by the complement of products found in this catalog, please contact an authorized Parker Automation Technology Center or a factory applications engineer.

Parker is proud to present these high precision products to you. We invite you to discover the advantages that can be realized by relying on Parker for products and systems which represent the very best value in the electromechanical marketplace.

Sincerely,

Ken Sweet
General Manager

Product Overview

Planetary Gearheads

Our new Generation II Stealth® Series provides higher radial load, increased service life and ease of mounting than comparably sized planetary gearheads. The Stealth Generation II Helical Planetary Gearheads incorporate design enhancements to provide superior performance for the most demanding high performance applications. For larger frame sizes, Parker offers Generation I Stealth® Series gearheads in 142 to

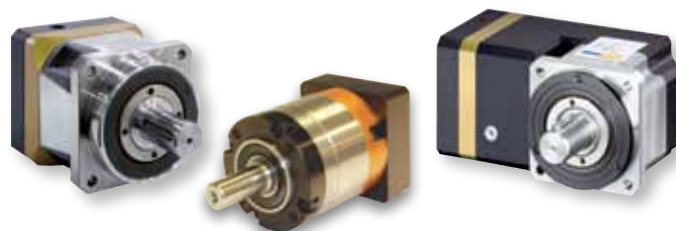

220 mm and NEMA 56 frame sizes. For standard precision applications, the PV Series gearhead combines power and versatility in an economical package available in a wide range of options.

Product Series	Gear Geometry	Performance	Configuration	Frame Size	Nominal Continuous Torque	Radial Load	Backlash arc-min	Page	
					Nm (in-lb)	N (lbs)			
Generation II Stealth®	PS	Helical Planetary	High Precision	In-Line	60 – 115 mm	27 – 230 (240 – 2047)	1650 – 7500 (370 – 1683)	8 – <3	12
	PX	Helical Planetary	Mid Precision	In-Line	60 – 115 mm NEMA 23 – 42	20 – 160 (178 – 1424)	1550 – 6800 (348 – 1526)	10 – <6	16
	RS	Helical Planetary/ Spiral Bevel	High Precision	Right Angle	60 – 115 mm	13 – 220 (115 – 1958)	1650 – 7500 (370 – 1683)	14 – <6	20
	RX	Helical Planetary/ Right Angle	Mid Precision	Right Angle	60 – 115 mm NEMA 23 – 42	10 – 136 (89 – 1210)	1550 – 6800 (348 – 1526)	20 – <12	24
Generation I Stealth®	PS	Helical Planetary	High Precision	In-Line	180 – 220 mm	294 – 1808 (2616 – 16,091)	7900 – 58,000 (1775 – 13,020)	8 – <3	30
	PX	Helical Planetary	Mid Precision	In-Line	142 mm NEMA 56	220 – 278 (1958 – 2474)	6000 (1347)	10 – <8	34
	RS	Helical Planetary/ Spiral Bevel	High Precision	Right Angle	180 – 220 mm	141 – 1808 (1255 – 16,091)	7900 – 58,000 (1775 – 13,020)	10 – <4	36
	PV	Planetary	Standard	In-Line	40 – 115 mm NEMA 17 – 42	3.5 – 148 (31 – 1317)	190 – 10,555 (43 – 2370)	15 – <12	40

MultiDrive Gearheads

Stealth® MultiDrive (MD) offers three different output options for true flexibility. MultiDrive models include low-ratio, dual-shaft and hollow-shaft options in a compact, right angle package. With 5 frame sizes and multiple ratios to choose from, you are guaranteed to find a Stealth® MultiDrive to fit your servo motor application.



Product Series	Gear Geometry	Performance	Configuration	Frame Size	Continuous Torque	Radial Load	Backlash arc-min	Page
					Nm (in-lb)	N (lbs)		
RT	Helical	High Precision	Right Angle Hollow Shaft	90 – 220 mm	23 – 565 (204 – 5178)	2800 – 7500 (692 – 1685)	<14 – <6	50
RD	Helical	High Precision	Right Angle Double Shaft	90 – 220 mm	30 – 150 (266 – 1328)	2800 – 7500 (692 – 1685)	<14 – <6	50
RB	Helical	High Precision	Right Angle Low Ratio	90 – 220 mm	35 – 190 (266 – 1682)	2800 – 7500 (692 – 1685)	<14 – <6	50

NEMA Gearheads

NEMA gearheads feature a high-efficiency spur gear design, in a light, compact package, and are ideal for applications requiring smooth operation and low starting torque. Ratios from 3:1 to 100:1 are available.



Product Series	Gear Geometry	Performance	Configuration	Frame Size	Continuous Radial Load		Backlash arc-min	Page
					Torque Nm (in-lb)	N		
NE	Spur Gear	Economy	In-Line	NEMA 23 – 42	6 – 40 (50 – 350)	90 – 890 (20 – 200)	10 – 30	58

Integral Solution Gearmotors

Stealth[®] Gearmotors represent the first time a brushless servo motor and a helical planetary gearhead have been integrated into a single product. Previously, engineers needing a gear drive with servo motor were forced to purchase the gearhead and motor separately. Parker Bayside manufactures precision gearheads and gearmotors under one roof.



Product Series	Gear Geometry	Performance	Configuration	Frame Size	Continuous Torque		Backlash arc-min	Page
					Nm (in-lb)	Feedback		
GM	Helical Planetary	Mid-Precision	In-Line	60 – 142 mm NEMA 23 – 56	3 – 60	Encoder/ Resolver	< 10	Consult Factory
DX	Planetary	Mid-Precision	In-Line	6 and 8 inch dia. Wheel Drive	26 – 48	Encoder	—	62

Application Examples

Plastic Bottle Extrusion

The manufacturer of high-performance plastic extrusion equipment needed a drop-in replacement gearhead for an existing worm gearbox used with their motor without having to alter the design of their machine. The gearhead/motor combination is being used to drive the machine's rollers, controlling the speed at which the plastic is extruded into high-quality plastic sheets. The smoothness of the rollers is critical to the quality of the plastic sheets being produced.



Application Challenges:

High Transmission Error and Velocity Ripple

The customer used worm gearheads to control the rollers. Worm gears exhibit a sliding action of involute gears instead of a rolling action, contributing to the lack of smoothness of the machine rollers. Due to the high transmission error and velocity ripple from the worm drive, the rollers operated at differing speeds. This produced small lines and imperfections on the plastic sheets, rendering it unusable.

High Wear and Low Efficiency

The high level of rubbing (sliding action) between the worm and wheel teeth in the worm gearhead caused a high gear-tooth-wear rate and a lower efficiency (70%) than other major gear types.

Parker SOLUTION:

Stealth PS Gearhead and RT MultiDrive (hollow shaft) Gearhead were used in combination to provide the required 120:1 ratio. The result was high-quality plastics sheets that exceeded the customer's specifications.



The Stealth's all-helical planetary design (HeliCrown Gear Tooth) features extremely high gear tooth accuracy, minimizing transmission error and velocity ripple. The HeliCrown design features extremely high efficiency (95%) while minimizing tooth wear by providing a pure rolling action. Parker's Plasma Nitriding heat-treating process further heightens the gear tooth's wear resistance.

The MultiDrive gearhead features a space-saving bore (hollow shaft) option, eliminating compliance that occurs when coupling a gearhead shaft to the rollers being driven. This solution can be used for a variety of applications, including packaging, food, semiconductor, automotive and medical.

Food/Packaging Automation

A manufacturer of machines for gluing, fill, sealing and diverting food containers for the food-processing industry had a requirement for the motor and gearhead to be mounted above the food plane. Certain modifications were also needed for the gearhead to make it safe for the food environment, and capable to withstand frequent washdowns.



Gearhead Design Considerations:

- **Lubrication – must be USDA food grade approved in case of incidental contact to food**
- **Sealing – must prevent any leaking as well as prevent any ingress of the fluid during washdown**
- **Finish – special FDA-approved finish must be used making it very durable and resistant to chipping, oxidizing or rusting**

- **Output Shaft – stainless steel prevents any rust from developing and contaminating the processing food.**

Parker SOLUTION:

Stealth PS planetary gearhead with standard F01 food grade special option



Stealth PS planetary gearhead with standard food grade option provides the gearhead with standard modifications including special lubrication, viton seals, special finish and a stainless steel output shaft.

Since this food grade modification is a standard option, delivery is only one week over the standard gearhead lead time. (Note: Similar standard modifications exist for vacuum, clean room, high temperature and radiation.)

High-Speed Milling

High-speed milling machines are commonplace in industries such as aerospace and automotive because they allow large structural components to be machined from one piece rather than assembled from many smaller subcomponents. For a customer that manufactures high-speed milling machines, spindle heads are operating at speeds ranging from 18,000 to 40,000 RPM, so that the cutting is above the resonant frequency of the machine. Because of this, many characteristics become more critical than with their standard machines. The extremely large size of the spindle head also posed problems for the manufacturer in trying to keep it accurately positioned during the milling stage.



Application Challenge:

Low Stiffness

The spindle head was moved rotationally by 2 bull gears, driving a large ring gear. Because of the system characteristics, it was difficult to keep the spindle head absolutely stiff during the milling process. The problems associated with low stiffness are:

- **Poor surface finish**
- **Accuracy errors**
- **Excessive tool chatter**
- **Reduced tool life**

Parker SOLUTION:

Two Stealth® PS Helical Planetary Gearheads were used in tandem to create a stiff platform for the spindle machine head. One gearhead, acting as the master, and the other as the slave, were attached to the bull gears to simultaneously turn the ring gear that positioned the machine head. While the master gearhead moved the ring, the slave was taking up the backlash. In this way, the precision gears allowed for the spindle to be moved accurately, while the two gearhead combination maintained maximum system stiffness.



Parker's Stealth PS gearhead features an all-helical planetary gear design. Helical gears have a much higher tooth-contact ratio and greater face width than straight-spur gears, providing higher loads, smoother tooth engagement and quieter operation. The Stealth's HeliCrown Gear Tooth design provides extremely high gear tooth accuracy, while minimizing tooth wear. Parker Bayside's Plasma Nitriding heat-treating process further heightens the gear tooth's wear resistance.

This solution can also be used in the aerospace and automotive industries.

High-, Mid- and Standard-Precision Planetary Gearheads

Helical planetary technology is superb for low-backlash, high-stiffness and high-accuracy requirements, making the Parker Generation II Stealth® line of helical planetary gearheads ideal for these high- and medium-level performance applications. The introduction of the PV Series gearhead completes the Parker gear family by offering a standard-grade gearhead with the highest radial load capacity available today in a cost-effective solution. Whether you need high-, medium- or standard-grade performance, Parker can match the need. All Parker gearheads are proudly manufactured in the USA in our state-of-the-art facility which, displays the best use of Lean manufacturing practices. For more information go to parkermotion.com.



Generation II Stealth® PS/PX/RS/RX:

Our new Generation II Stealth® series provides higher radial load, increased service life and ease of mounting

The Generation II Stealth® Helical Planetary Gearheads incorporate design enhancements to provide superior performance for the most demanding high performance applications.

Stealth Generation II incorporates dual angular contact bearings providing higher radial load capacities while maintaining high input speeds. Design enhancements also include full complement needle bearings allowing for increased service life and extended warranties. Internal design changes and optimized gearing geometries allow for one oil fill level for any orientation, resulting in shortened part number designation and simplified order placement.

Universal mounting kits provide common mounting kits across multiple product lines to promote quicker deliveries and ease of mounting to any servo motor. Applications that require either high precision (PS/RS Series Gearheads) or mid-range precision (PX/

RX Series Gearheads) utilize the same mounting kit part numbers within the same frame size.

Mounting to any servo motor is as easy as A-B-C (adapter, bushing, collet).

Features & Benefits

- **Higher radial load capacity: widely spaced angular contact output bearings**
- **Increased service life: full complement of planet needle bearings**
- **Universal mounting kits: quicker deliveries and easier mounting**
- **High torque and low backlash: helical planetary gearing**
- **High stiffness: Integral ring gear and rigid sun gear**
- **Higher gear wear resistance: plasma nitriding heat treating**
- **PX models are optionally available with flange mounting for easy installation. (Contact factory for flange mount availability for RX models.)**



Other Planetary Gearheads:

Generation I Stealth® PS, PX and RS Gearheads

For larger frame sizes, Parker offers Generation I Stealth® Series gearheads in 142 to 220 mm and NEMA 56 frame sizes.

PV Series Precision Gearheads

The PV Series gearhead combines power and versatility in an economical package. It comes in a wide range of options including dimensional output face crossovers to the Parker Bayside PX, Alpha LP, Neugart PLE, Stober PE and Standard NEMA gearheads.



Standard Options for Planetary Gearheads

Gearheads Ready to Mount to Linear Actuators

Most belt driven linear slides need a gearhead to reduce inertia. Parker has pre-engineered in-line and right-angle gearheads to mount directly to most popular linear slides, eliminating the need for couplings or adapters.



Input Shaft Speed Reducer/Speed Increaser for Increased Design Flexibility

Parker gearheads are available with an input-shaft option. The input-shaft option allows more design flexibility, as options like brakes, encoders, or safety couplings can be used between the motor and the gearhead. This option also allows you to operate the gearhead as a speed increaser.



Mil-Spec Gearheads

Parker has extensive experience in military and aerospace applications. The Stealth Bomber, M1 Tank and the Space Shuttle all use Parker gearheads. Parker's quality system has been approved by NASA and the US Government to MIL-I-45208A.



Special Environments

Put a Parker gearhead anywhere! Parker can supply gearheads to operate in the harshest environments:



Vacuum - Available as a standard option to 10⁻⁶ Torr vacuum ratings.

Clean Room - Special gearheads for Class 10,000 clean room applications.

High Temperature - Special lubricants and seals for temperatures up to 250° C.

Radiation - Gearheads customized to operate within radioactive environments.

Food Grade/Washdown - Gearheads customized to operate within food-handling and washdown environments.

Planetary Gearhead Selection Overview

Product Series	Gear Geometry	Performance	Configuration	Frame Size	Nominal Continuous Torque	Radial Load	Backlash arc-min	Page	
					Nm (in-lb)	N (lbs)			
Generation II Stealth®	PS	Helical Planetary	High Precision	In-Line	60 – 115 mm	27 – 230 (240 – 2047)	1650 – 7500 (370 – 1683)	8 – <3	12
	PX	Helical Planetary	Mid Precision	In-Line	60 – 115 mm NEMA 23 – 42	20 – 160 (178 – 1424)	1550 – 6800 (348 – 1526)	10 – <6	16
	RS	Helical Planetary/ Spiral Bevel	High Precision	Right Angle	60 – 115 mm	13 – 220 (115 – 1958)	1650 – 7500 (370 – 1683)	14 – <6	20
	RX	Helical Planetary/ Right Angle	Mid Precision	Right Angle	60 – 115 mm NEMA 23 – 42	10 – 136 (89 – 1210)	1550 – 6800 (348 – 1526)	20 – <12	24
Generation I Stealth®	PS	Helical Planetary	High Precision	In-Line	180 – 220 mm	294 – 1808 (2616 – 16,091)	7900 – 58,000 (1775 – 13,020)	8 – <3	30
	PX	Helical Planetary	Mid Precision	In-Line	142 mm NEMA 56	220 – 278 (1958 – 2474)	6000 (1347)	10 – <8	34
	RS	Helical Planetary/ Spiral Bevel	High Precision	Right Angle	180 – 220 mm	141 – 1808 (1255 – 16,091)	7900 – 58,000 (1775 – 13,020)	10 – <4	36
	PV	Planetary	Standard	In-Line	40 – 115 mm NEMA 17 – 42	3.5 – 148 (31 – 1317)	190 – 10,555 (43 – 2370)	15 – <12	40

Helical Planetary Gearhead Features

Parker planetary gearheads incorporate the latest technology enhancements...

- **Latest technology in seals to reduce heat and wear**
- **Oil lubrication reduces friction and operating temperature, increasing gear life**



Helical Planetary Design

Helical gears have more tooth contact and greater face width than spur gears. This results in higher loads, smoother tooth engagement, quieter operation and lower backlash.



“The Helical Advantage”

Parker planetary gearheads are a superior design with construction integrity to deliver power, speed and accuracy – quietly and efficiently.

HeliCrown®

Parker developed the HeliCrown gear tooth to further optimize Stealth's® performance. Since most vibration occurs at the entry and exit points of a gear tooth, HeliCrown eliminates metal only in these areas, without sacrificing gear strength, producing a quieter and stronger gear.

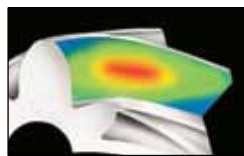

Power... 30% more torque than comparably sized gearheads

Speed... up to 6,000 RPM input speeds

Accuracy... Less than 3 arc-minutes backlash

Quiet... Less than 68 dB noise

Efficiency... Over 97% efficiency

Plasma Nitriding

Parker's in-house Plasma Nitriding process results in an ideal gear tooth. The surface is very hard (65 Rc) and the core is strong, but flexible (36 Rc). The result is a wear-resistant gear tooth that can withstand heavy shock, ensuring high accuracy for the life of the gearhead.



ServoMount®

Parker's ServoMount design features a balanced input gear supported by a floating bearing. This unique design compensates for motor shaft runout and misalignment, ensuring TRUE alignment of the input sun gear with the planetary section and allowing input speeds up to 6,000 RPM. ServoMount ensures error-free installation to any motor, in a matter of minutes.



Parker Stealth® planetary gearhead features

Features unique to Generation II Stealth® gearheads

- **Widely spaced angular contact bearings provide higher radial load capacity**
- **Full compliment of needle bearings for increased service life**
- **Universal mounting kits offer easier mounting and quick delivery**

Common features for all Generation I & II Stealth® gearheads

- ① **Helical Planetary** - Provides smooth, quiet operation, high torque and high accuracy.
- ② **ServoMount®** - Motor-mounting design ensures error-free installation and the balanced pinion allows higher input speeds.
- ③ **Precision Bearings** - Provide high speed and high radial and axial load capacity.
- ④ **HeliCrown®** - Parker's proprietary gear tooth geometry ensures quieter operation and higher loads than conventional gears.
- ⑤ **Sealed Unit** - Viton seals and O-Rings provide IP65 protection to prevent leaks and protect against harsh environments.
- ⑥ **Integral Ring Gear** - Cutting the ring gear directly into the housing allows for larger bearing and planet gears, delivering maximum power and stiffness in a minimum package.

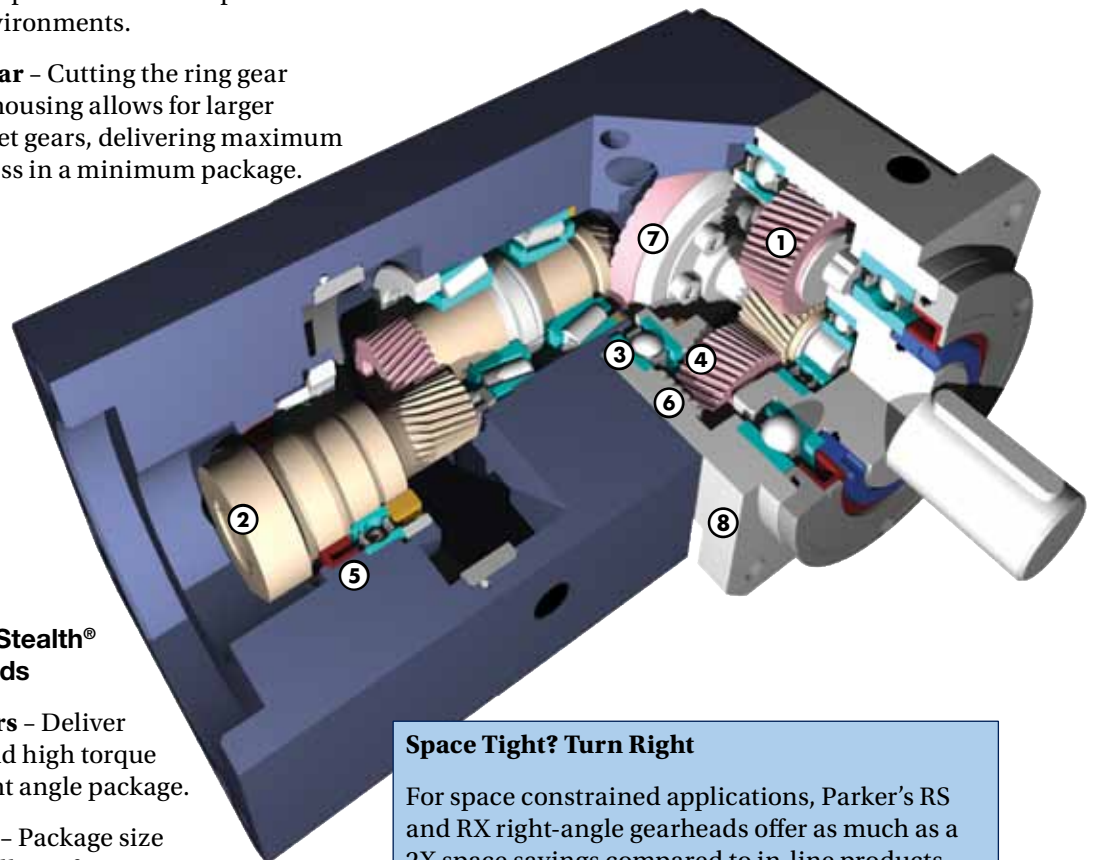
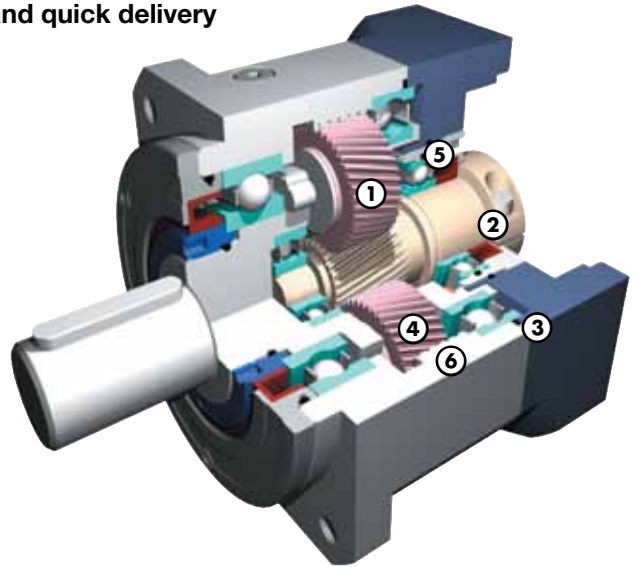

Features unique to Stealth® right-angle gearheads

- ⑦ **Spiral Bevel Gears** - Deliver high efficiency and high torque in a compact, right angle package.
- ⑧ **Compact Design** - Package size is the same regardless of ratio.

Space Tight? Turn Right

For space constrained applications, Parker's RS and RX right-angle gearheads offer as much as a 2X space savings compared to in-line products.

Generation II Stealth® Series

PS Generation II Performance Specifications

Parameter	Units	Ratio	PS60 Gen II	PS90 Gen II	PS115 Gen II	PS142 Gen II
Nominal Output Torque ¹⁾ $T_{nom r}$	Nm (in-lb)	3,15,30	27 (239)	76 (673)	172 (1522)	300 (2656)
		4,5,7,20,25,40,50,70	37 (327)	110 (974)	230 (2036)	430 (3807)
		10,100	32 (283)	93 (823)	205 (1814)	310 (2745)
Maximum Acceleration Output Torque ²⁾ $T_{acc r}$	Nm (in-lb)	3,15,30	34 (300)	105 (930)	225 (1990)	450 (3984)
		4,5,7,20,25,40,50,70	48 (425)	123 (1090)	285 (2525)	645 (5711)
		10,100	37 (325)	112 (990)	240 (2125)	465 (4117)
Emergency Stop Output Torque ³⁾ $T_{em r}$	Nm (in-lb)	3,15,30	80 (710)	260 (2300)	600 (5310)	1100 (9739)
		4,5,7,20,25,40,50,70	70 (620)	230 (2035)	500 (4425)	970 (8588)
		10,100	60 (530)	200 (1770)	430 (3805)	830 (7349)
Nominal Input Speed $N_{nom r}$	RPM	3	3000	2500	2000	1500
		4,5	3500	3000	2500	2000
		7,10,15	4000	3500	3000	2500
		20,25,30	4500	4000	3500	3000
		40,50	4800	4400	3800	3200
		70,100	5200	4800	4200	3600
Maximum Input Speed $N_{max r}$ ⁴⁾	RPM	3 – 100	6000	5500	4500	4000
Maximum Radial Load Pr_{max} ^{5,7)}	N (lbs)		1650 (370)	4800 (1080)	7500 (1685)	10,000 (2247)
Maximum Axial Load Pa_{max} ⁶⁾	N (lbs)		2100 (475)	3600 (810)	6800 (1530)	8800 (1976)
Service Life	h		20,000			
Standard Backlash ⁸⁾	arc-min	3 – 10	<6	<6	<4	<4
		15 – 100	<8	<8	<6	<6
Low Backlash ⁸⁾	arc-min	3 – 10	<4	<4	<3	<3
		15 – 100	<6	<6	<5	<5
Efficiency at Nominal Torque	%	3 – 10	97	97	97	97
		15 – 100	94	94	94	94
Noise Level at 3000 RPM ⁹⁾	db	3 – 100	<62	<62	<65	<66
Torsional Stiffness	Nm/arc-min (in-lb/arc-min)	3 – 100	3 (27)	12 (105)	27 (240)	50 (438)
Maximum Allowable Case Temperature	° C	3 – 100	-20 to 90			
Lubrication		3 – 100	Per Maintenance Schedule			
Mounting Position		3 – 100	Any			
Direction of Rotation		3 – 100	Same as Input			
Degree of Protection			IP65			
Maximum Weight	kg (lbs)	3 – 10	1.3 (2.9)	3.0 (6.6)	7.0 (15.4)	14.0 (30.0)
		15 – 100	1.7 (3.7)	5.0 (11.0)	10.0 (22.0)	20.0 (43.0)

1) At nominal speed $N_{nom r}$.

2) Parker MotionSizer sizing software available for free download at parkermotion.com.

3) Maximum of 1000 stops.

4) For intermittent operation.

5) Max radial load applied to the center of the shaft at 100 rpm.

6) Max axial load at 100 rpm.

7) For combined radial and axial load consult factory.

8) Measured at 2% of rated torque.

9) Measure at 1m.

PS Generation II Output Shaft Load Rating

Formulas below graphs are used to calculate radial load (P_{rx}) at any distance "X" from the gearhead mounting surface:

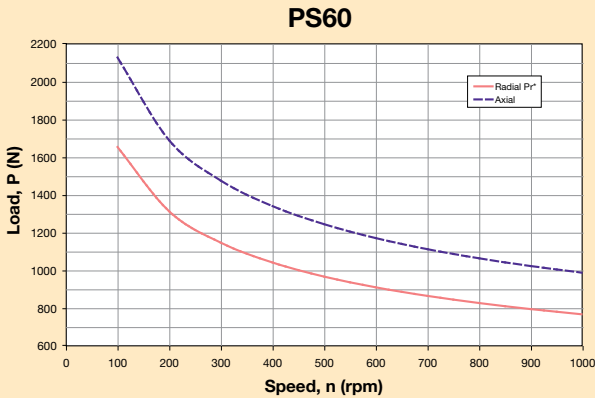

$$P_{rx} = Pr * 75 \text{ mm} / (49 + X)$$

$$P_{rx} = Pr * 2.95 \text{ in} / (1.93 \text{ in} + X)$$

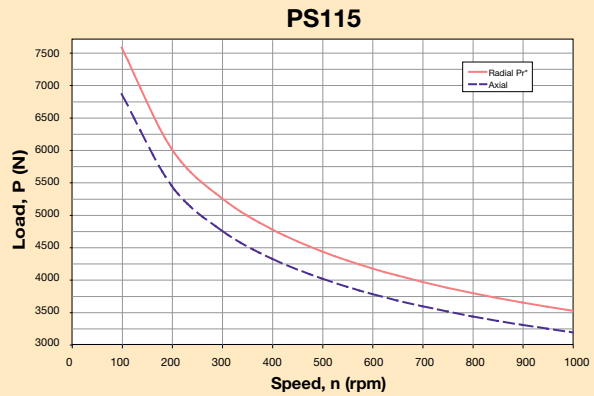

$$P_{rx} = Pr * 124 \text{ mm} / (81 + X)$$

$$P_{rx} = Pr * 4.88 \text{ in} / (3.19 \text{ in} + X)$$

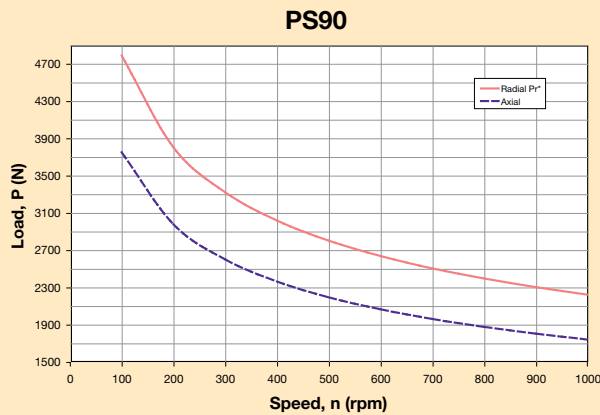

$$P_{rx} = Pr * 96 \text{ mm} / (62 + X)$$

$$P_{rx} = Pr * 3.78 \text{ in} / (2.44 \text{ in} + X)$$

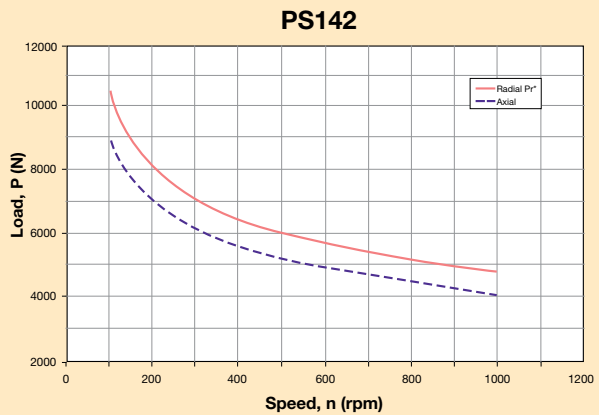

$$P_{rx} = Pr * 156 \text{ mm} / (93 + X)$$

$$P_{rx} = Pr * 6.14 \text{ in} / (3.66 \text{ in} + X)$$

* Radial load applied to center of the shaft.

Generation II Stealth® Series

PS Generation II Dimensions

Free 3D Solid Models and drawings available at parkermotion.com

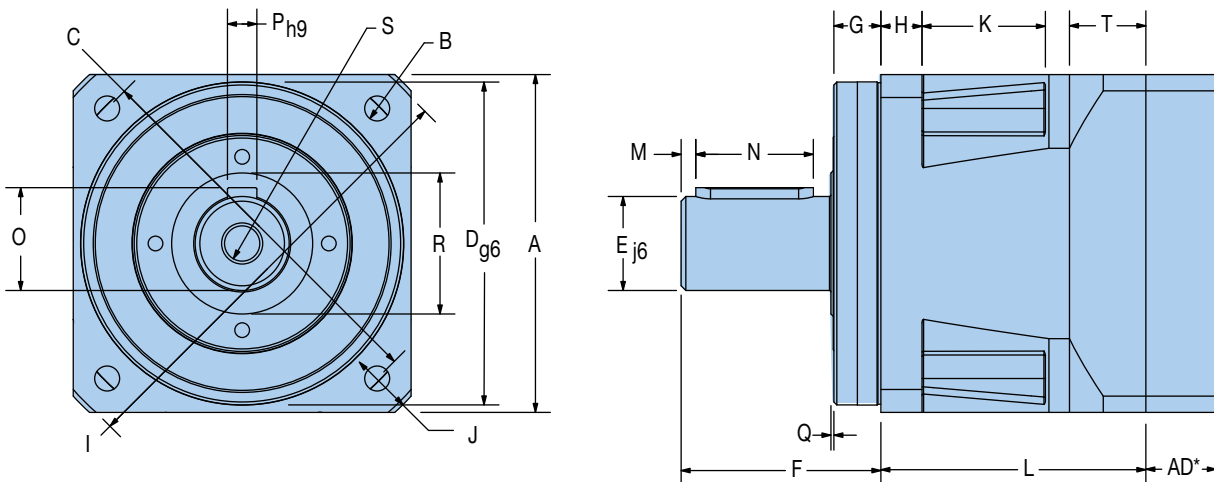

Metric Frame Sizes

Frame Size	A		B		C		D		E		F		G	
	Square Flange		Bolt Hole		Bolt Circle		Pilot Diameter		Output Shaft Diameter		Output Shaft Length		Pilot Thickness	
	mm	in	mm	in	mm	in	mm	in	mm	in	mm	in	mm	in
PS60	62	2.441	5.5	0.217	70	2.756	50	1.969	16	0.630	40	1.575	11	0.433
PS90	90	3.543	6.5	0.256	100	3.937	80	3.150	22	0.866	52	2.047	15	0.591
PS115	115	4.528	8.5	0.335	130	5.118	110	4.331	32	1.260	68	2.677	16	0.630
PS142	142	5.591	11.0	0.433	165	6.496	130	5.118	40	1.575	102	4.016	20	0.787

Frame Size	H		I		J		K		L1		L2		M	
	Flange Thickness		Housing Diameter		Housing Recess		Recess Length		Length (3-10 Ratios)		Length (15-100 Ratios)		Distance from Shaft End	
	mm	in	mm	in	mm	in	mm	in	mm	in	mm	in	mm	in
PS60	8	0.315	80	3.150	5	0.197	24	0.945	59.8	2.354	94.8	3.732	2	0.079
PS90	10	0.394	116	4.567	6.5	0.256	33	1.299	69.5	2.736	113	4.449	3	0.118
PS115	14	0.551	152	5.984	7.5	0.295	42	1.654	90.2	3.551	143.4	5.646	5	0.197
PS142	15	0.591	185	7.283	10.0	0.394	45	1.772	103.7	4.083	170.7	6.720	5	0.197

Frame Size	N		O		P		Q		R		S		T	
	Keyway Length		Key Height		Keyway Width		Shoulder Height		Shoulder Diameter		Tap & Depth (end of shaft)		Rear Housing Thickness	
	mm	in	mm	in	mm	in	mm	in	mm	in			mm	in
PS60	25	0.984	18	0.709	5	0.197	1	0.039	22	0.866	M5x8		20.3	0.799
PS90	32	1.260	24.5	0.965	6	0.236	1	0.039	35	1.378	M8x16		20	0.787
PS115	40	1.575	35	1.378	10	0.394	1.5	0.059	50	1.969	M12x25		26	1.024
PS142	63	2.480	43	1.693	12	0.472	2.5	0.098	78	3.071	M16x32		31	1.220

PS Generation II Universal Mounting Kit*

Adapter Length “AD” Dimension

Frame Size	Motor Shaft Length		Gearhead Adapter Length	
	mm	in	mm	in
60	16 – 35	0.630 – 1.378	16.5	0.65
	35.1 – 41	1.382 – 1.614	22.5	0.886
90	20 – 40	0.787 – 1.575	20	0.787
	40.1 – 48	1.579 – 1.890	28.5	1.122
115	22 – 50	0.866 – 1.969	24	0.945
	50.1 – 61	1.972 – 2.402	35	1.378
142	26 – 62	1.023 – 2.441	30	1.181
	62.1 – 82	2.445 – 3.228	50	1.969

* Know your motor and need our mounting kit part number? See page 29 or use our Motor Mounting Search Tool on our website at: www.parkermotion.com

PS Generation II Inertia

All moment of inertia values are as reflected at the input of the gearhead

Ratio	Units*	PS60	PS90	PS115	PS142
3	kg-cm ²	0.2500	0.9700	3.4000	14.8000
	in-lb-sec ²	0.000221	0.000858	0.003009	0.013098
4	kg-cm ²	0.1700	0.6700	2.2000	9.8000
	in-lb-sec ²	0.000150	0.000593	0.001947	0.008673
5	kg-cm ²	0.1500	0.5100	1.7000	7.0000
	in-lb-sec ²	0.000133	0.000451	0.001505	0.006195
7	kg-cm ²	0.1400	0.4100	1.3000	5.3000
	in-lb-sec ²	0.000124	0.000363	0.001151	0.004691
10	kg-cm ²	0.1400	0.3700	1.1000	4.4000
	in-lb-sec ²	0.000124	0.000327	0.000974	0.003894
15	kg-cm ²	0.1500	0.5200	0.1700	6.4000
	in-lb-sec ²	0.150000	0.000460	0.000150	0.005664
20	kg-cm ²	0.1500	0.5100	1.7000	6.4000
	in-lb-sec ²	0.000133	0.000451	0.001505	0.005664
25	kg-cm ²	0.1500	0.5100	1.7000	6.4000
	in-lb-sec ²	0.000133	0.000451	0.001505	0.005664
30, 40, 50, 70, 100	kg-cm ²	0.1300	0.3700	1.1000	4.2000
	in-lb-sec ²	0.000115	0.000327	0.000974	0.003717

* Note: 1 kg-cm² = 0.000885 in-lb-sec²

Generation II Stealth® Series

PX Generation II Performance Specifications

Parameter	Units	Ratio	PX60 Gen II		PX90 Gen II		PX115 Gen II	
Nominal Output Torque ¹⁾ T_{nom r}	Nm (in-lb)	3,15,30	20	(177)	56	(496)	120	(1062)
		4,5,7,20,25,40,50,70	32	(283)	66	(584)	152	(1345)
		10,100	25	(221)	60	(531)	160	(1416)
Maximum Acceleration Output Torque ²⁾ T_{acc r}	Nm (in-lb)	3,15,30	27	(240)	84	(743)	180	(1593)
		4,5,7,20,25,40,50,70	39	(345)	98	(867)	228	(2018)
		10,100	30	(265)	90	(797)	192	(1700)
Emergency Stop Output Torque ³⁾ T_{em r}	Nm (in-lb)	3,15,30	64	(565)	208	(1840)	480	(4248)
		4,5,7,20,25,40,50,70	56	(495)	184	(1628)	400	(3540)
		10,100	48	(425)	160	(1416)	344	(3044)
Nominal Input Speed N_{nom r}	RPM	3	3000		2500		2000	
		4,5	3500		3000		2500	
		7,10,15	4000		3500		3000	
		20,25,30	4500		4000		3500	
		40,50	4800		4400		3800	
		70,100	5200		4800		4200	
Maximum Input Speed N_{max r} ⁴⁾	RPM	3 – 100	6000		5500		4500	
Maximum Radial Load Pr_{max} ^{5,7)}	N (lbs)		1550 (348)		2800 (630)		5500 (1235)	
Maximum Axial Load Pa_{max} ⁶⁾	N (lbs)		2100 (475)		3600 (810)		6800 (1530)	
Service Life	h				20,000			
Standard Backlash ⁸⁾	arc-min	3 – 10	<10		<9		<8	
		15 – 100	<12		<11		<10	
Low Backlash ⁸⁾	arc-min	3 – 10	<8		<7		<6	
		15 – 100	<10		<9		<8	
Efficiency at Nominal Torque	%	3 – 10	97		97		97	
		15 – 100	94		94		94	
Noise Level at 3000 RPM ⁹⁾	db	3 – 100	<62		<62		<65	
Torsional Stiffness	Nm/arc-min (in-lb/arc-min)	3 – 100	2.5 (22)		10 (90)		22 (195)	
Maximum Allowable Case Temperature	° C	3 – 100			-20 to 90			
Lubrication		3 – 100	Per Maintenance Schedule					
Mounting Position		3 – 100	Any					
Direction of Rotation		3 – 100	Same as Input					
Degree of Protection			IP65					
Maximum Weight	kg (lbs)	3 – 10	1.0 (2.2)		3.0 (6.6)		7.0 (15.4)	
		15 – 100	2.0 (4.4)		5.0 (11.0)		10.0 (22.0)	

1) At nominal speed N_{nom r}.

2) Parker MotionSizer sizing software available for free download at parkermotion.com.

3) Maximum of 1000 stops.

4) For intermittent operation.

5) Max radial load applied to the center of the shaft at 100 rpm.

6) Max axial load at 100 rpm.

7) For combined radial and axial load consult factory.

8) Measured at 2% of rated torque.

9) Measure at 1m.

PX Generation II Output Shaft Load Rating

PX60 / PX23

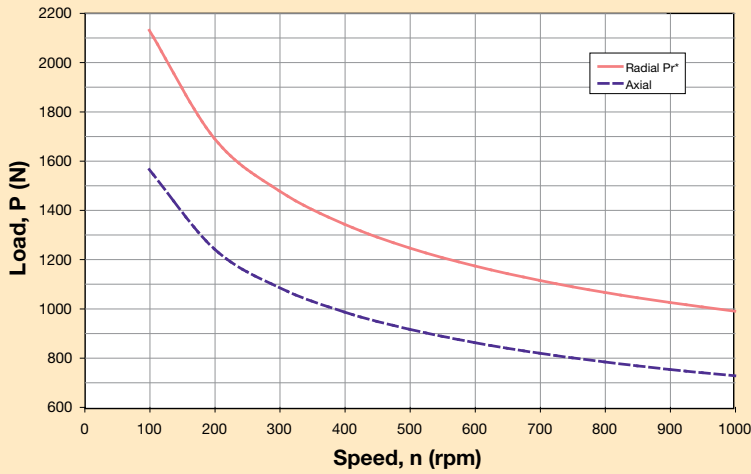

Formulas to calculate radial load (Prx) at any distance "X" from the gearhead mounting surface:

$$Prx = Pr * 78 \text{ mm} / (63 + X)$$

$$Prx = Pr * 3.07 \text{ in} / (2.48 \text{ in} + X)$$

PX90 / PX34

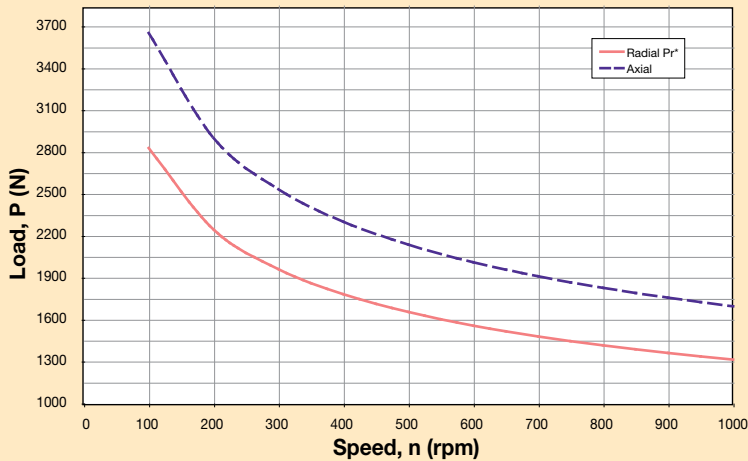

$$Prx = Pr * 95 \text{ mm} / (73 + X)$$

$$Prx = Pr * 3.74 \text{ in} / (2.87 \text{ in} + X)$$

PX115 / PX42

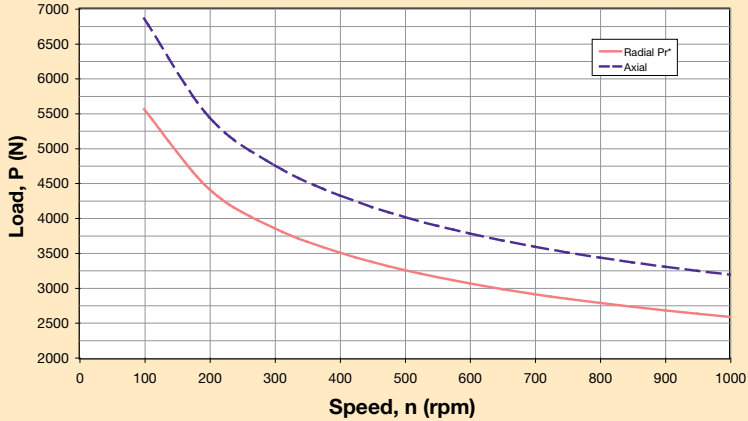

$$Prx = Pr * 115 \text{ mm} / (73 + X)$$

$$Prx = Pr * 4.53 \text{ in} / (3.43 \text{ in} + X)$$

* Radial load applied to center of the shaft.

Generation II Stealth® Series

PX Generation II Dimensions

Free 3D Solid Models and drawings available at parkermotion.com

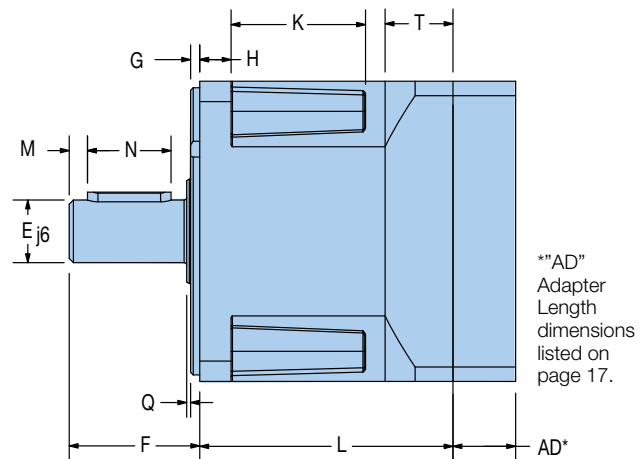
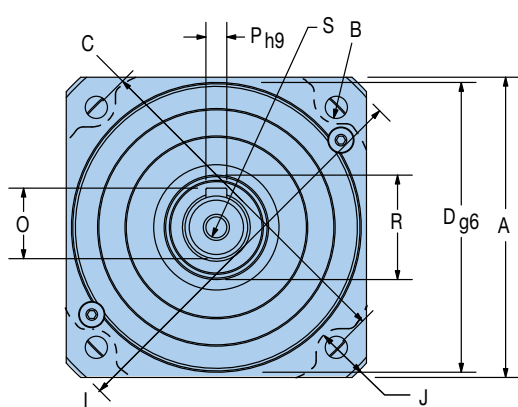

AD
Adapter
Length
dimensions
listed on
page 17.

Metric Frame Sizes

Frame Size	A	B	C	D	E	F	G	H	I	J	K
	Square Flange	Flange Bolt Hole	Flange Bolt Circle	Pilot Diameter	Output Shaft Diameter	Output Shaft Length	Pilot Thickness	Flange Thickness	Housing Diameter	Housing Recess	Recess Length
	mm in	mm in	mm in	mm in	mm in	mm in	mm in	mm in	mm in	mm in	mm in
PX60	62 2.441	5.5 0.217	70 2.756	50 1.969	16 0.630	25 0.984	2.5 0.098	8 0.315	82 3.228	5 0.197	24 0.945
PX90	90 3.543	6.5 0.256	100 3.937	80 3.150	20 0.787	40 1.575	3 0.118	10 0.394	116 4.567	6.5 0.256	33 1.299
PX115	115 4.528	8.5 0.335	130 5.118	110 4.331	24 0.945	50 1.969	3.5 0.138	14 0.551	152 5.984	7.5 0.295	42 1.654

Frame Size	L1	L2	M	N	O	P	Q	R	S	T
	Length Single Stage	Length Double Stage	Distance from Shaft End	Keyway Length	Key Height	Keyway Width	Shoulder Height	Shoulder Diameter	Tap & Depth (end of shaft)	Rear Housing Thickness
	mm in	mm in	mm in	mm in	mm in	mm in	mm in	mm in	mm in	mm in
PX60	70.3 2.768	105.34 4.146	3 0.118	16 0.630	18 0.709	5 0.197	1 0.039	21 0.827	M5x8	20.3 0.799
PX90	80 3.150	123.54 4.862	5 0.197	28 1.102	22.5 0.886	6 0.236	1 0.039	29 1.142	M8x16	20 0.787
PX115	97 3.819	150.25 5.913	7 0.276	32 1.260	27 1.063	8 0.315	1.5 0.059	36 1.417	M8x16	26 1.024

NEMA Frame Sizes

Frame Size	B		C		D		E		F		N		O		P	
	Bolt Hole		Bolt Circle		Pilot Diameter		Output Shaft Diameter		Output Shaft Length		Keyway Length		Keyway Depth		Keyway Width	
	in	mm	in	mm	in	mm	in	mm	in	mm	in	mm	in	mm	in	mm
PX23	0.2	4.953	2.625	66.675	1.5	38.100	0.38	9.525	1	25.400	—	—	—	—	—	—
PX34	0.22	5.512	3.88	98.425	2.88	73.025	0.5	12.700	1.25	31.750	1.06	27.000	0.07	1.829	0.13	3.251
PX42	0.28	7.137	4.95	125.730	2.19	55.550	0.63	15.875	1.5	38.100	1.14	29.007	0.09	2.388	0.19	4.775

PX23 has a flat on output shaft, not a keyway

NOTE: NEMA Sizes have 20% lower torque/stiffness ratings due to smaller output shaft diameter.

PX Flange Mount Option Dimensions

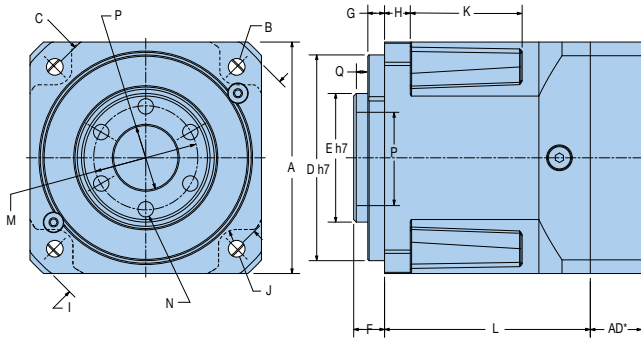

Dimensions A through D and H through L2 are the same as the metric frame dimensions shown on the previous page 18.

Frame Size	E		F		G	
	Output Hollow Shaft Diameter		Output Hollow Shaft Depth		Pilot Thickness	
	mm	in	mm	in	mm	in
PX60-T01	32	1.26	7.5	0.30	2.5	0.10
PX90-T01	50	1.97	12	0.47	6.5	0.26
PX115-T01	70	2.76	14.5	0.57	8.5	0.33

PX Generation II Universal Mounting Kits*

Adapter Length "AD" Dimension

Frame Size	Motor Shaft Length		Gearhead Adapter Length	
	mm	in	mm	in
60	16 – 35	0.630 – 1.378	16.5	0.65
	35.1 – 41	1.382 – 1.614	22.5	0.886
90	20 – 40	0.787 – 1.575	20	0.787
	40.1 – 48	1.579 – 1.890	28.5	1.122
115	22 – 50	0.866 – 1.969	24	0.945
	50.1 – 61	1.972 – 2.402	35	1.378

Frame Size	M		N		P		Q	
	Shaft Bolt Circle	mm	in	Tap Size	Shaft Pilot Diameter	mm	in	Shaft Pilot Depth
PX60-T01	25	0.984	M5 x 0.8	18	0.709	4	0.157	
PX90-T01	40	1.575	M6 x 1	25	0.984	5	0.197	
PX115-T01	55	2.165	M8 x 1.25	40	1.575	5.5	0.217	

* Know your motor and need our mounting kit part number? See page 29 or use our Motor Mounting Search Tool on our website at: www.parkermotion.com

PX Generation II Inertia

All moment of inertia values are as reflected at the input of the gearhead

Ratio	Units*	PX60 / PX23	PX90 / PX34	PX115 / PX42
3	kg-cm ²	0.2500	0.9700	3.4000
	in-lb-sec ²	0.000221	0.000858	0.003009
4	kg-cm ²	0.1700	0.6700	2.2000
	in-lb-sec ²	0.000150	0.000593	0.001947
5	kg-cm ²	0.1500	0.5100	1.7000
	in-lb-sec ²	0.000133	0.000451	0.001505
7	kg-cm ²	0.1400	0.4100	1.3000
	in-lb-sec ²	0.000124	0.000363	0.001151
10	kg-cm ²	0.1400	0.3700	1.1000
	in-lb-sec ²	0.000124	0.000327	0.000974
15	kg-cm ²	0.1500	0.5200	0.1700
	in-lb-sec ²	0.150000	0.000460	0.000150
20	kg-cm ²	0.1500	0.5100	1.7000
	in-lb-sec ²	0.000133	0.000451	0.001505
25	kg-cm ²	0.1500	0.5100	1.7000
	in-lb-sec ²	0.000133	0.000451	0.001505
30, 40, 50, 70, 100	kg-cm ²	0.1300	0.3700	1.1000
	in-lb-sec ²	0.000115	0.000327	0.000974

* Note: 1 kg-cm² = 0.000885 in-lb-sec²

Generation II Stealth® Series

RS Generation II Performance Specifications

Parameter	Units	Ratio	RS60 Gen II		RS90 Gen II		RS115 Gen II		RS142 Gen II	
Nominal Output Torque ¹⁾ $T_{nom r}$	Nm (in-lb)	5	13	(115)	55	(487)	85	(752)	225	(1992)
		10	24	(212)	80	(708)	160	(1415)	365	(3232)
		15,20,25,50	35	(310)	88	(779)	220	(1947)	430	(3807)
		30,40,100	30	(266)	86	(752)	195	(1726)	310	(2745)
Maximum Acceleration Output Torque ²⁾ $T_{acc r}$	Nm (in-lb)	5	19	(168)	83	(743)	127	(1124)	337	(2984)
		10	36	(320)	120	(743)	240	(2124)	547	(4843)
		15,20,25,50	45	(400)	123	(867)	255	(2257)	645	(5711)
		30,40,100	37	(327)	112	(797)	240	(2124)	465	(4717)
Emergency Stop Output Torque ³⁾ $T_{em r}$	Nm (in-lb)	5	40	(355)	150	(1327)	270	(2390)	625	(5534)
		10	72	(637)	240	(2125)	480	(4248)	1000	(8854)
		15,20,25,50	80	(708)	250	(2213)	510	(4514)	1100	(9739)
		30,40,100	60	(531)	200	(1770)	430	(3806)	830	(7349)
Nominal Input Speed $N_{nom r}$	RPM	5 to 10	3200		2800		2400		2000	
		15,20,25,30,40	3700		3300		2900		2500	
		50,100	4200		3800		3400		3000	
Maximum Input Speed $N_{max r}$ ⁴⁾	RPM	5 – 100	6000		5300		4500		3800	
Maximum Radial Load $P_{r,max}$ ^{5,7)}	N (lbs)		1650	(370)	4800	(1080)	7500	(1685)	10,000	(2247)
Maximum Axial Load $P_{a,max}$ ⁶⁾	N (lbs)		2100	(475)	3600	(810)	6800	(1530)	8800	(1976)
Service Life	h		20,000							
Standard Backlash ⁸⁾	arc-min	5 – 10	<14		<12		<12		<10	
		15 – 100	<12		<10		<10		<8	
Low Backlash ⁸⁾	arc-min	5 – 10	<10		<8		<8		<6	
		15 – 100	<8		<6		<6		<4	
Efficiency at Nominal Torque	%	5 – 100	94		94		94		94	
Noise Level at 3000 RPM ⁹⁾	db	5 – 100	<65		<68		<68		<70	
Torsional Stiffness	Nm/arc-min (in-lb/arc-min)	5 – 100	2.5	(22)	10	(90)	22	(195)	42	(372)
Maximum Allowable Case Temperature	° C	5 – 100	-20 to 90							
Lubrication		5 – 100	Per Maintenance Schedule							
Mounting Position		5 – 100	Any							
Degree of Protection			IP65							
Maximum Weight	kg (lbs)	5 – 100	2.0	(4.4)	6.0	(13.2)	11.0	(24.2)	24	(52)

1) At nominal speed $N_{nom r}$.

2) Parker MotionSizer sizing software available for free download at parkermotion.com.

3) Maximum of 1000 stops.

4) For intermittent operation.

5) Max radial load applied to the center of the shaft at 100 rpm.

6) Max axial load at 100 rpm.

7) For combined radial and axial load consult factory.

8) Measured at 2% of rated torque.

9) Measure at 1m.

RS Generation II Output Shaft Load Rating

Formulas below graphs are used to calculate radial load (Prx) at any distance "X" from the gearhead mounting surface:

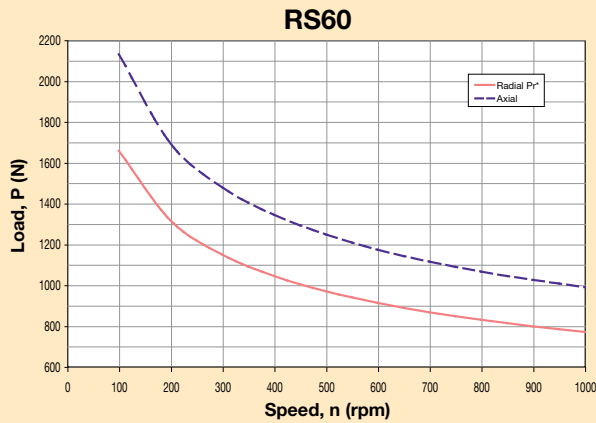

$$Pr_x = Pr * 75 \text{ mm} / (49 + X)$$

$$Pr_x = Pr * 2.95 \text{ in} / (1.93 \text{ in} + X)$$

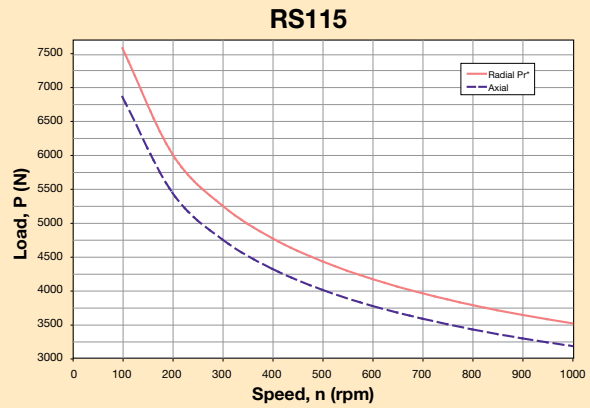

$$Pr_x = Pr * 124 \text{ mm} / (81 + X)$$

$$Pr_x = Pr * 4.88 \text{ in} / (3.19 \text{ in} + X)$$

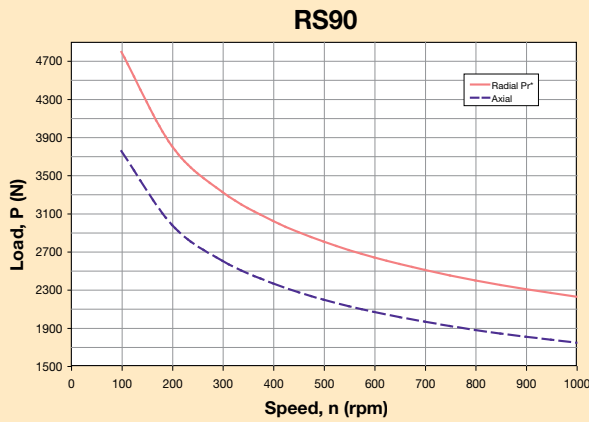

$$Pr_x = Pr * 96 \text{ mm} / (62 + X)$$

$$Pr_x = Pr * 3.78 \text{ in} / (2.44 \text{ in} + X)$$

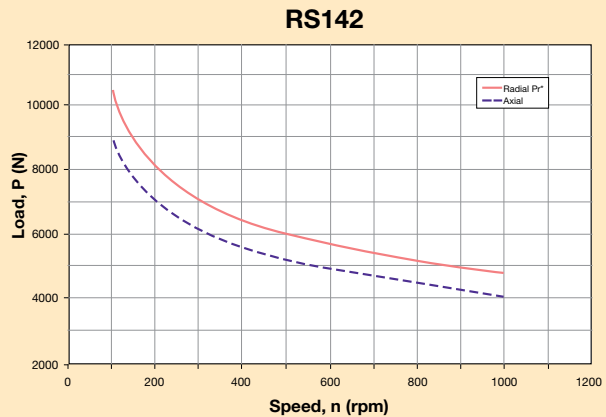

$$Pr_x = Pr * 156 \text{ mm} / (93 + X)$$

$$Pr_x = Pr * 6.14 \text{ in} / (3.66 \text{ in} + X)$$

* Radial load applied to center of the shaft.

Generation II Stealth® Series

RS Generation II Dimensions

Free 3D Solid Models and drawings available at parkermotion.com

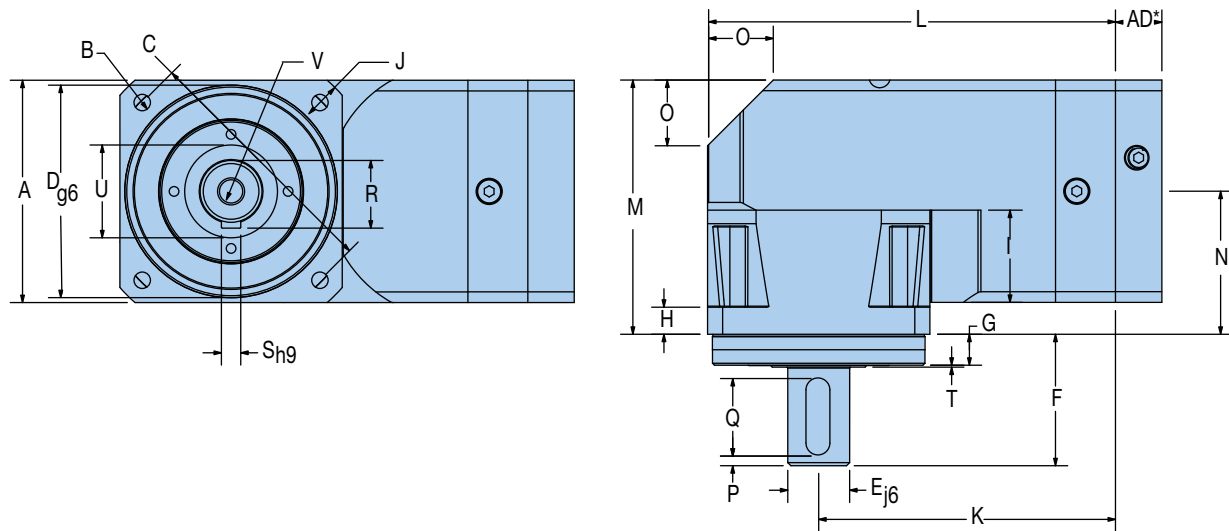

Metric Frame Sizes

Frame Size	A		B		C		D		E		F		G		H	
	Square Flange		Bolt Hole		Bolt Circle		Pilot Diameter		Output Shaft Diameter		Output Shaft Length		Pilot Thickness		Flange Thickness	
	mm	in	mm	in	mm	in	mm	in	mm	in	mm	in	mm	in	mm	in
RS60	62	2.441	5.5	0.217	70	2.756	50	1.969	16	0.630	40	1.575	11	0.433	8	0.315
RS90	90	3.543	6.5	0.256	100	3.937	80	3.150	22	0.866	52	2.047	15	0.591	10	0.394
RS115	115	4.528	8.5	0.335	130	5.118	110	4.331	32	1.260	68	2.677	16	0.630	14	0.551
RS142	142	5.591	11.0	0.433	165	6.496	130	5.118	40	1.575	102	4.016	20	0.787	15	0.591

Frame Size	I		J		K		L		M		N		O		P	
	Recess Length		Housing Recess		Distance to Output Centerline		Housing Length		Housing Width		Distance to Input Centerline		Taper Distance		Distance from Shaft End	
	mm	in	mm	in	mm	in	mm	in	mm	in	mm	in	mm	in	mm	in
RS60	23.5	0.925	5.0	0.197	66.0	2.598	124.7	4.909	78.0	3.071	47.0	1.850	15	0.591	2	0.079
RS90	33.0	1.299	6.5	0.256	132.0	5.197	177.0	6.969	103.0	4.055	58.0	2.283	27	1.063	3	0.118
RS115	42.0	1.653	7.5	0.295	153.5	6.043	211.0	8.307	132.0	5.177	74.0	2.913	34	1.339	5	0.197
RS142	56.5	2.224	10.0	0.394	198.5	7.815	269.5	10.610	158.2	6.228	87.2	3.433	42	1.654	5	0.197

Frame Size	Q		R		S		T		U		V
	Keyway Length		Key Height		Keyway Width		Shoulder Height		Shoulder Diameter		
	mm	in	mm	in	mm	in	mm	in	mm	in	Tap & Depth (end of shaft)
RS60	25	0.984	18.0	0.709	5	0.197	0.5	0.020	22	0.866	M5x8
RS90	32	1.260	24.5	0.965	6	0.236	0.5	0.020	35	1.378	M8x16
RS115	40	1.575	35.0	1.378	10	0.394	1	0.039	45	1.772	M12x25
RS142	63	2.480	43.0	1.693	12	0.472	2.5	0.098	78	3.071	M16x32

RS Generation II Universal Mounting Kits*

Adapter Length “AD” Dimension

Frame Size	Motor Shaft Length		Gearhead Adapter Length	
	mm	in	mm	in
60	16 – 35	0.630 – 1.378	16.5	0.65
	35.1 – 41	1.382 – 1.614	22.5	0.886
90	20 – 40	0.787 – 1.575	20	0.787
	40.1 – 48	1.579 – 1.890	28.5	1.122
115	22 – 50	0.866 – 1.969	24	0.945
	50.1 – 61	1.972 – 2.402	35	1.378
142	26 – 62	1.023 – 2.441	30	1.181
	62.1 – 82	2.445 – 3.228	50	1.969

* Know your motor and need our mounting kit part number? See page 29 or use our Motor Mounting Search Tool on our website at: www.parkermotion.com

RS Generation II Inertia

All moment of inertia values are as reflected at the input of the gearhead

Ratio	Units*	RS60	RS90	RS115	RS142
5	kg-cm ²	0.2200	0.8100	2.5000	9.4000
	in-lb-sec ²	0.000195	0.000717	0.002213	0.008319
10	kg-cm ²	0.1900	0.6100	1.9000	6.7000
	in-lb-sec ²	0.000168	0.000540	0.001682	0.005929
15	kg-cm ²	0.1800	0.6000	1.7000	6.6000
	in-lb-sec ²	0.150000	0.000531	0.001505	0.005841
20	kg-cm ²	0.1700	0.5100	1.4000	5.2000
	in-lb-sec ²	0.000150	0.000451	0.001239	0.004602
25	kg-cm ²	0.1600	0.4200	1.3000	4.5000
	in-lb-sec ²	0.000142	0.000372	0.001151	0.003983
30	kg-cm ²	0.1800	0.6000	1.7000	6.7000
	in-lb-sec ²	0.000159	0.000531	0.001505	0.005929
40	kg-cm ²	0.1700	0.5100	1.4000	5.2000
	in-lb-sec ²	0.000150	0.000451	0.001239	0.004602
50	kg-cm ²	0.1500	0.4000	1.1000	3.4000
	in-lb-sec ²	0.000133	0.000354	0.000974	0.003009
100	kg-cm ²	0.1500	0.4000	1.1000	3.4000
	in-lb-sec ²	0.000133	0.000354	0.000974	0.003009

* Note: 1 kg-cm² = 0.000885 in-lb-sec²

Generation II Stealth® Series

RX Generation II Performance Specifications

Parameter	Units	Ratio	RX60 Gen II		RX90 Gen II		RX115 Gen II	
Nominal Output Torque ¹⁾ $T_{nom r}$	Nm (in-lb)	5	10	(89)	44	(390)	68	(602)
		10	19	(168)	64	(566)	128	(566)
		15,20,25,50	24	(212)	66	(585)	136	(584)
		30,40,100	20	(177)	60	(530)	128	(531)
Maximum Acceleration Output Torque ²⁾ $T_{acc r}$	Nm (in-lb)	5	15	(133)	66	(584)	102	(903)
		10	28	(248)	96	(850)	128	(1132)
		15,20,25,50	36	(319)	100	(885)	136	(1203)
		30,40,100	30	(266)	90	(797)	128	(1132)
Emergency Stop Output Torque ³⁾ $T_{em r}$	Nm (in-lb)	5	32	(283)	120	(1062)	216	(1912)
		10	58	(513)	192	(1700)	384	(3398)
		15,20,25,50	64	(566)	200	(1770)	408	(3611)
		30,40,100	48	(425)	160	(1416)	345	(3053)
Nominal Input Speed $N_{nom r}$	RPM	5,10	3200		2800		2400	
		15,20,25,30,40	3700		3300		2900	
		50,100	4200		3800		3400	
Maximum Input Speed $N_{max r}$ ⁴⁾	RPM	5 – 100	6000		5300		4500	
Maximum Radial Load Pr_{max} ^{5,7)}	N (lbs)		1550	(348)	2800	(1079)	5500	(1236)
Maximum Axial Load Pa_{max} ⁶⁾	N (lbs)		2100	(475)	3600	(810)	6800	(1530)
Service Life	h				20,000			
Standard Backlash ⁸⁾	arc-min	5 – 10	<20		<18		<16	
		15 – 100	<20		<18		<16	
Low Backlash ⁸⁾	arc-min	5 – 10	<18		<16		<14	
		15 – 100	<16		<14		<12	
Efficiency at Nominal Torque	%	5 – 100	94		94		94	
Noise Level at 3000 RPM ⁹⁾	db	5 – 100	<65		<68		<68	
Torsional Stiffness	Nm/arc-min (in-lb/arc-min)	5 – 100	2.5	(22)	10	(90)	22	(195)
Maximum Allowable Case Temperature	° C	5 – 100	-20 to 90					
Lubrication		5 – 100	Per Maintenance Schedule					
Mounting Position		5 – 100	Any					
Degree of Protection			IP65					
Maximum Weight	kg (lbs)	5 – 100	2.0	(4.4)	6.0	(13.2)	11.0	(24.2)

1) At nominal speed $N_{nom r}$.

2) Parker MotionSizer sizing software available for free download at parkermotion.com.

3) Maximum of 1000 stops.

4) For intermittent operation.

5) Max radial load applied to the center of the shaft at 100 rpm.

6) Max axial load at 100 rpm.

7) For combined radial and axial load consult factory.

8) Measured at 2% of rated torque.

9) Measure at 1m.

RX Generation II Output Shaft Load Rating

RX60 / RX23

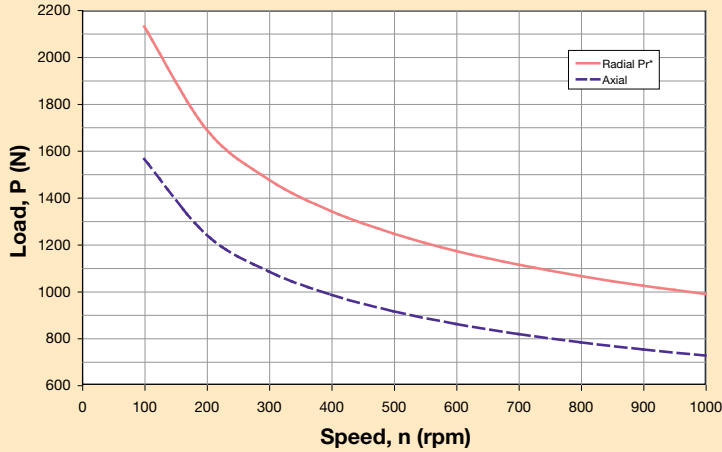

Formulas to calculate radial load (Prx) at any distance "X" from the gearhead mounting surface:

$$Prx = Pr * 78 \text{ mm} / (63 + X)$$

$$Prx = Pr * 3.07 \text{ in} / (2.48 \text{ in} + X)$$

RX90 / RX34

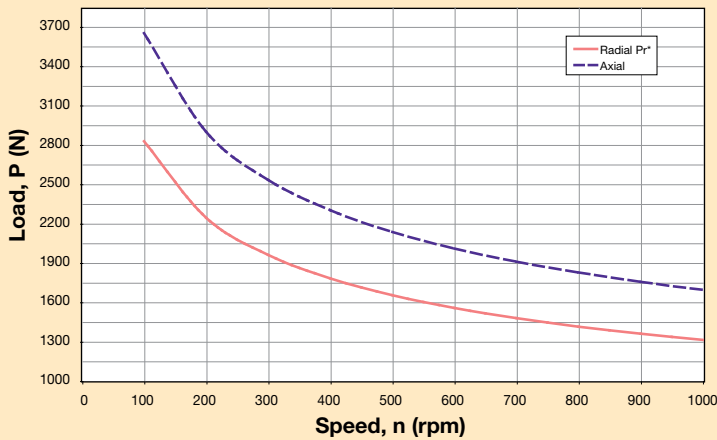

$$Prx = Pr * 95 \text{ mm} / (73 + X)$$

$$Prx = Pr * 3.74 \text{ in} / (2.87 \text{ in} + X)$$

RX115 / RX42

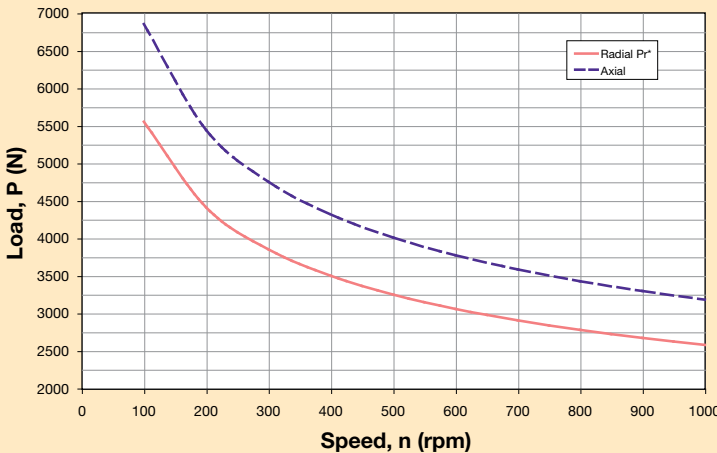

$$Prx = Pr * 115 \text{ mm} / (73 + X)$$

$$Prx = Pr * 4.53 \text{ in} / (3.43 \text{ in} + X)$$

* Radial load applied to center of the shaft.

Generation II Stealth® Series

RX Generation II Dimensions

Free 3D Solid Models and drawings available at parkermotion.com

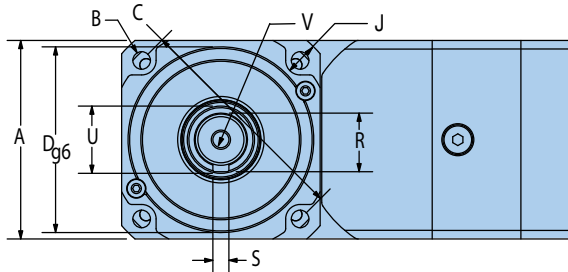

RX Gearheads also available with Flange Mount Option – Contact Factory

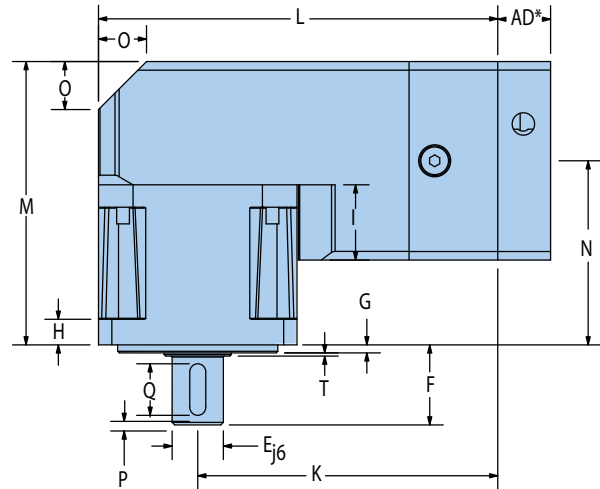

Metric Frame Sizes

Frame Size	A		B		C		D		E		F		G		H		I		J		K	
	Square Flange		Bolt Hole		Bolt Circle		Pilot Diameter		Output Shaft Diameter		Output Shaft Length		Pilot Thickness		Flange Thickness		Recess Length		Housing Recess		Distance to Output Centerline	
	mm	in	mm	in	mm	in	mm	in	mm	in	mm	in	mm	in	mm	in	mm	in	mm	in	mm	in
RX60	62	2.441	5.5	0.217	70	2.756	50	1.969	16	0.630	25	0.984	2.5	0.098	13	0.512	23.5	0.925	5	0.197	93.7	3.689
RX90	90	3.543	6.5	0.256	100	3.937	80	3.150	20	0.787	40	1.575	3	0.118	17	0.669	36.5	1.437	6.5	0.256	132	5.197
RX115	115	4.528	8.5	0.335	130	5.118	110	4.331	24	0.945	50	1.969	3.5	0.138	20	0.787	47.5	1.870	7.5	0.295	153.5	6.043

Frame Size	L		M		N		O		P		Q		R		S		T		U		V	
	Housing Length		Housing Width		Distance to Input Centerline		Taper Distance		Distance from Shaft End		Keyway Length		Keyway Key Height		Keyway Width		Shoulder Height		Shoulder Diameter		Tap & Depth (end of shaft)	
	mm	in	mm	in	mm	in	mm	in	mm	in	mm	in	mm	in	mm	in	mm	in	mm	in	mm	in
RX60	124.5	4.902	88.5	3.484	57.5	2.264	14	0.551	3	0.118	16	0.630	18	0.709	5	0.197	0.5	0.020	21	0.827	M5x8	
RX90	177	6.969	114	4.469	68.5	2.697	25	0.984	5	0.197	28	1.102	24.5	0.965	6	0.236	0.5	0.020	29	1.142	M8x16	
RX115	211	8.307	138	5.445	81	3.189	32	1.260	7	0.276	32	1.260	27	1.063	8	0.315	1	0.039	36	1.417	M8x16	

NEMA Frame Sizes

Frame Size	B		C		D		E		F		Q		R		S	
	Bolt Hole		Bolt Circle		Pilot Diameter		Output Shaft Diameter		Output Shaft Length		Keyway Length		Keyway Depth		Keyway Width	
	in	mm	in	mm	in	mm	in	mm	in	mm	in	mm	in	mm	in	mm
RX23	0.2	4.953	2.625	66.675	1.5	38.100	0.38	9.525	1	25.400	—	—	—	—	—	—
RX34	0.22	5.512	3.88	98.425	2.88	73.025	0.5	12.700	1.25	31.750	1.06	27.000	0.07	1.829	0.13	3.251
RX42	0.28	7.137	4.95	125.730	2.19	55.550	0.63	15.875	1.5	38.100	1.14	29.007	0.09	2.388	0.19	4.775

RX23 has a flat on output shaft, not a keyway

NOTE: NEMA Sizes have 20% lower torque/stiffness ratings due to smaller output shaft diameter.

RX Generation II Universal Mounting Kits*

Adapter Length “AD” Dimension

Frame Size	Motor Shaft Length		Gearhead Adapter Length	
	mm	in	mm	in
60	16 – 35	0.630 – 1.378	16.5	0.65
	35.1 – 41	1.382 – 1.614	22.5	0.886
90	20 – 40	0.787 – 1.575	20	0.787
	40.1 – 48	1.579 – 1.890	28.5	1.122
115	22 – 50	0.866 – 1.969	24	0.945
	50.1 – 61	1.972 – 2.402	35	1.378

* Know your motor and need our mounting kit part number? See page 29 or use our Motor Mounting Search Tool on our website at: www.parkermotion.com

RX Generation II Inertia

All moment of inertia values are as reflected at the input of the gearhead

Ratio	Units*	RX60 / RX23	RS90 / RX34	RS115 / RX42
5	kg-cm ²	0.2200	0.8100	2.5000
	in-lb-sec ²	0.000195	0.000717	0.002213
10	kg-cm ²	0.1900	0.6100	1.9000
	in-lb-sec ²	0.000168	0.000540	0.001682
15	kg-cm ²	0.1800	0.6000	1.7000
	in-lb-sec ²	0.150000	0.000531	0.001505
20	kg-cm ²	0.1700	0.5100	1.4000
	in-lb-sec ²	0.000150	0.000451	0.001239
25	kg-cm ²	0.1600	0.4200	1.3000
	in-lb-sec ²	0.000142	0.000372	0.001151
30	kg-cm ²	0.1800	0.6000	1.7000
	in-lb-sec ²	0.000159	0.000531	0.001505
40	kg-cm ²	0.1700	0.5100	1.4000
	in-lb-sec ²	0.000150	0.000451	0.001239
50	kg-cm ²	0.1500	0.4000	1.1000
	in-lb-sec ²	0.000133	0.000354	0.000974
100	kg-cm ²	0.1500	0.4000	1.1000
	in-lb-sec ²	0.000133	0.000354	0.000974

* Note: 1 kg-cm² = 0.000885 in-lb-sec²

Generation II Stealth® Series

Generation II Stealth® How to Order

Choose gearhead series, frame size, ratio, backlash and specify motor, make and model for mounting kit from the charts below and on the following page.

Sizing/Selection Design Assistance

To properly size and select a gearhead for a specific application requires consideration of several interrelated parameters including: speed, continuous torque, repetitive peak torque or acceleration torque, emergency stop torque, duty cycle, ambient temperature and radial and axial shaft load.

The 9 step procedure on pages 72-73 provides a straightforward method of selecting the correct gearhead for your application.

Gearhead Ordering Information

Order Example:					
①	②	③	④	⑤	⑥
PS	60	-	003	-	S 2
①	②	③	④	⑤	⑥
Series	Frame Size	Ratio	Special Options*	Backlash	GEN 2 Identifier
PS	60, 90, 115, 142	003, 004, 005, 007, 010, 015, 020, 025, 030, 040, 050, 070, 100	XXX = Factory issued		
PX	60, 90, 115, 23, 34, 42	003, 004, 005, 007, 010, 015, 020, 025, 030, 040, 050, 070, 100	XXX = Factory issued T01 = Flange Mount	S = Standard L = Low	2
RS	60, 90, 115, 142	005, 010, 015, 020, 025, 030, 040, 050, 100	XXX = Factory issued		
RX	60, 90, 115, 23, 34, 42	005, 010, 015, 020, 025, 030, 040, 050, 100	XXX = Factory issued (Contact factory for Flange Mount Option)		

* Standard special options include: F01 Food Grade, W01 Washdown, G01 GenI Spacer Plate, L02 No lubricant (standard is oil filled), V01 Vacuum, C01 CleanRoom Class 10,000. Leave blank if no special option required.

Motor Mounting How to Order

Know your motor and need our mounting kit part number? Use the charts below or use our Motor Mounting Search Tool on our website at:

www.parkermotion.com

Order Example:	7	8		
	MU	60	-	XXX

7	8
Universal Mounting*	Frame Size **
MU	60, 90, 115
Mounting Kit Suffix Number	
See Motor Mounting Selection Tool on our website at: www.parkermotion.com	

* Common to PS, PX, RS and RX Series Gearheads
 **PX/RX23 use MU60, PX/RX34 use MU90, PX/RX42 use MU115

Universal Mounting Kit Adapter Length “AD” Dimension

Frame Size	Motor Shaft Length		Gearhead Adapter Length	
	mm	in	mm	in
60	16 – 35	0.630 – 1.378	16.5	0.65
	35.1 – 41	1.382 – 1.614	22.5	0.886
90	20 – 40	0.787 – 1.575	20	0.787
	40.1 – 48	1.579 – 1.890	28.5	1.122
115	22 – 50	0.866 – 1.969	24	0.945
	50.1 – 61	1.972 – 2.402	35	1.378
142	26 – 62	1.023 – 2.44	30	1.181
	46 – 82	1.811 – 3.23	50	1.969

Recommended Parker Motor and Mounting Kit

Frame Size	Recommended Servo Motor			Recommended Stepper Motor		
	Motor	Mounting Kit	AD Dimension	Motor	Mounting Kit	AD Dimension
60 or 23	BE23 SM23	MU60-033	16.5 mm	LV23 HV23	MU60-005	16.5 mm
90 or 34	MPP092 BE34	MU90-092 MU90-005	20 mm	LV34 HV34	MU90-005	20 mm
115 or 42	MPP100 MPP115	MU-115-039 MU115-010	24 mm			
142	MPP115 MPP142	MU142-010 Mu142-146	30 mm			

Generation I Stealth® Series

PS Performance Specifications

Parameter	Units	Ratio	PS180		PS220	
Nominal Output Torque $T_{nom r}$	Nm (in-lb)	3,4,5,7,10	735	(6500)	1413	(12,500)
		15,20,25,30,40,50	1017	(9000)	1808	(16,000)
		70,100	893	(7900)	1582	(14,000)
Maximum Acceleration Output Torque ¹⁾ $T_{acc r}$	Nm (in-lb)	3,4,5,7,10 70,100	972	(8600)	1763	(15,600)
		15,20,25,30,40,50	1198	(10,600)	2011	(17,800)
Emergency Stop Output Torque ²⁾ $T_{em r}$	Nm (in-lb)	3,4,5,7,10 70,100	2237	(19,800)	4068	(36,000)
		15,20,25,30,40,50	2757	(24,400)	4520	(40,000)
Nominal Input Speed $N_{nom r}$	RPM	3,4,5		1600		1200
		7,10		2000		1500
		15,20,25,30,40,50		2400		1800
		70,100		2800		2100
Maximum Input Speed $N_{max r}$	RPM	3 – 100		3000		2300
Standard Backlash ³⁾	arc-min	3 – 10		4		4
		15 – 100		6		6
Low Backlash ³⁾	arc-min	3 – 10		3		3
		15 – 100		5		5
Efficiency at Nominal Torque	%	3 – 10		97		97
		15 – 100		94		94
Noise Level at: 2000 RPM ⁴⁾ 3000 RPM ⁴⁾	db	3 – 100		66		68
				—		—
Torsional Stiffness	Nm/arc-min (in-lb/arc-min)	3 – 100	110	(973)	210	(1,858)
Maximum Allowable Case Temperature	° C	3 – 100			-20 to 90	
Degree of Protection					IP65	
Maximum Weight	kg (lbs)	3 – 10	26	(57)	49	(108)
		15 – 100	35	(77)	71	(157)

1) Parker MotionSizer sizing software available for free download at parkermotion.com.

2) Maximum of 1,000 stops

3) Measured at 2% of rated torque

4) Measured at 1 meter

PS Output Shaft Load Rating

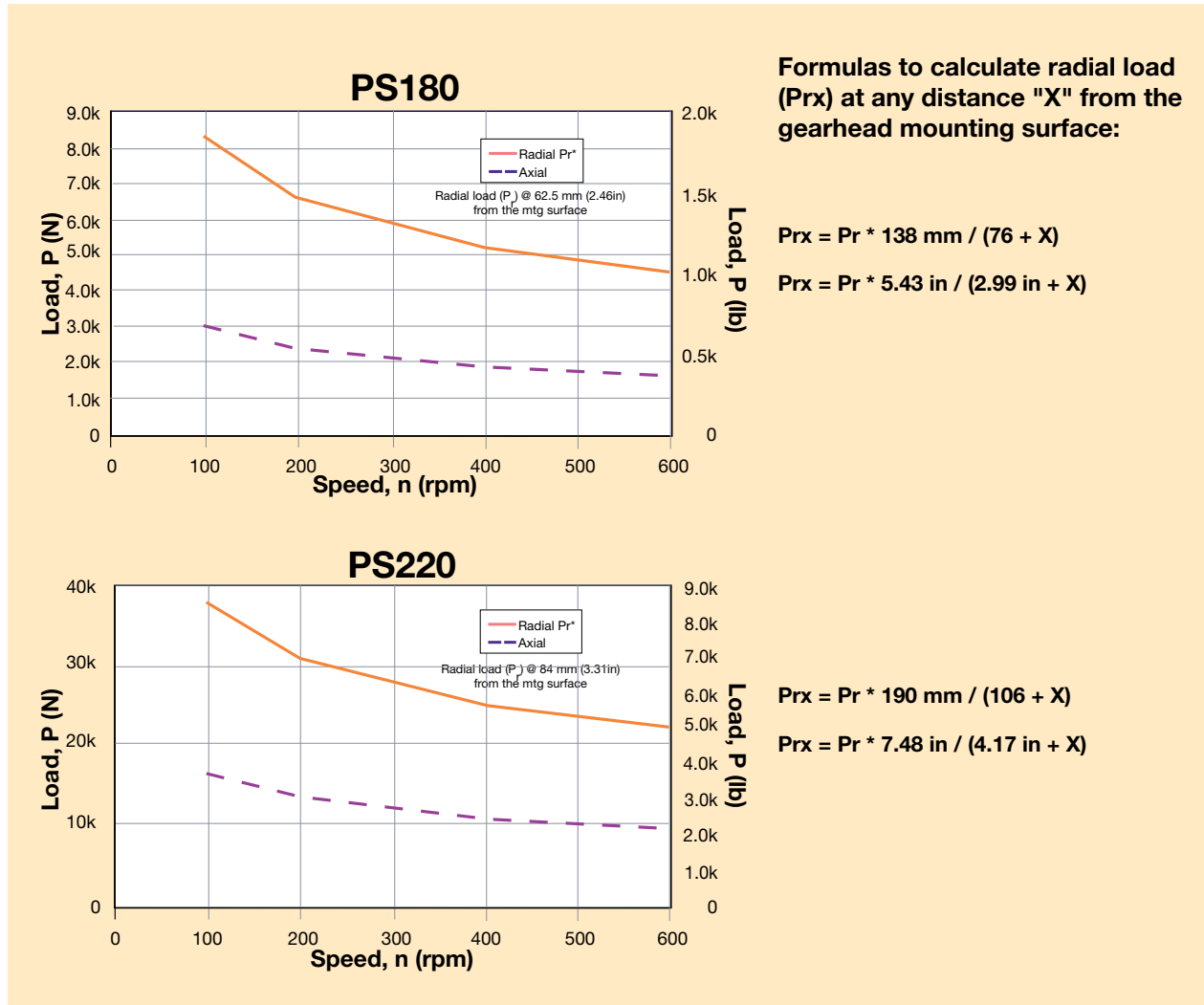

* Radial load applied to center of the shaft.

Generation I Stealth® Series

PS Dimensions

Free 3D Solid Models and drawings available at parkermotion.com

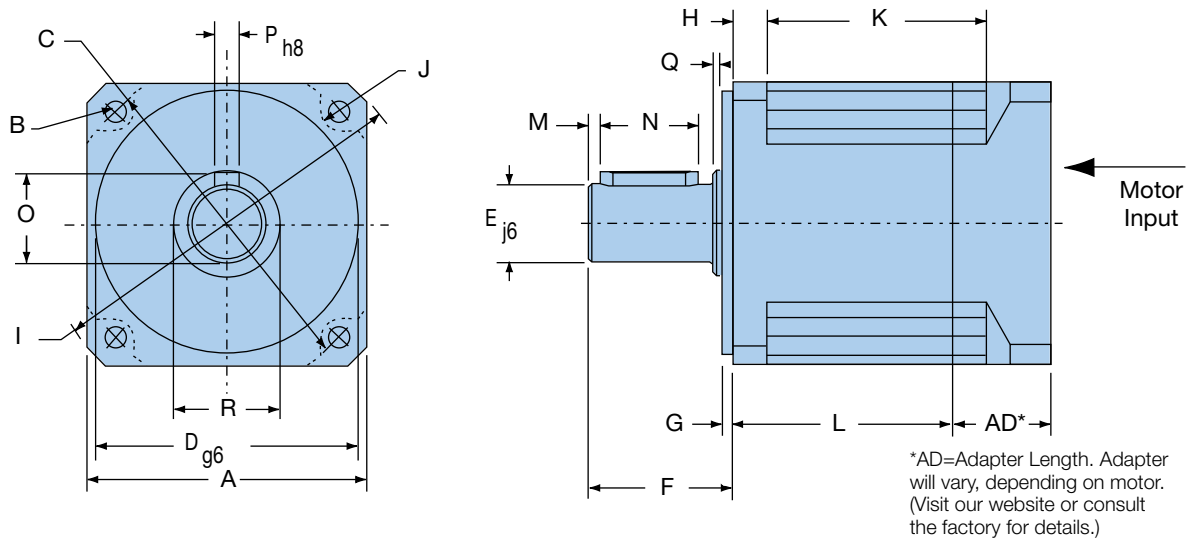

Metric Frame Sizes

Frame Size	A		B		C		D		E		F		G		H		I		J	
	mm	in	mm	in	mm	in	mm	in	mm	in	mm	in	mm	in	mm	in	mm	in	mm	in
PS180	182	7.165	13	0.512	215	8.465	160	6.299	55	2.165	105	4.134	20	0.787	16	0.630	240	9.449	16	0.630
PS220	220	8.661	17	0.669	250	9.843	180	7.087	75	2.953	138	5.433	30	1.181	22	0.866	290	11.417	16	0.630

Frame Size	K1		K2		L1		L2		M		N		O		P		Q		R	
	mm	in	mm	in	mm	in	mm	in	mm	in	mm	in	mm	in	mm	in	mm	in	mm	in
PS180	88	3.465	158	6.220	83.5	3.287	153.5	6.043	6	0.236	70	2.756	59	2.323	16	0.630	3	0.118	70	2.756
PS220	116	4.567	218	8.583	108	4.252	210.5	8.287	6	0.236	90	3.543	79.5	3.130	20	0.787	3	0.118	95	3.740

PS Inertia

All moment of inertia values are as reflected at the input of the gearhead

	Ratio	Units	Frame Size	
			PS180	PS220
Small Motor Shaft Diameter Range	3 to 100	mm	15.9-35	24-48
		in	0.626-1.378	0.945-1.89
	3	gm-cm-sec ²	28.6	—
		oz-in-sec ²	0.397	—
	4, 5	gm-cm-sec ²	17.6	62.6
		oz-in-sec ²	0.244	0.869
	7, 10	gm-cm-sec ²	9.24	34.3
		oz-in-sec ²	0.128	0.476
	15	gm-cm-sec ²	15.8	51.0
		oz-in-sec ²	0.219	0.708
	20, 25	gm-cm-sec ²	16.7	53.3
		oz-in-sec ²	0.232	0.741
	30, 40, 50, 70, 100	gm-cm-sec ²	7.450	27.1
		oz-in-sec ²	0.104	0.377

	Ratio	Units	Frame Size	
			PS180	PS220
Large Motor Shaft Diameter Range	3 to 100	mm	35-42	48-55
		in	1.38-1.65	1.89-2.17
	3	gm-cm-sec ²	37.8	111
		oz-in-sec ²	0.526	1.54
	4, 5	gm-cm-sec ²	25.6	72.4
		oz-in-sec ²	0.356	1.01
	7, 10	gm-cm-sec ²	15.8	44.1
		oz-in-sec ²	0.219	0.613
	15	gm-cm-sec ²	23.8	60.8
		oz-in-sec ²	0.331	0.845
	20, 25	gm-cm-sec ²	24.7	62.9
		oz-in-sec ²	0.344	0.874
	30, 40, 50, 70, 100	gm-cm-sec ²	14.0	37.0
		oz-in-sec ²	0.195	0.513

Generation I Stealth® Series

PX Performance Specifications

Parameter	Units	Ratio	PX142 / PX56	
Nominal Output Torque $T_{nom r}$	Nm (in-lb)	3, 4, 5	226	(1,994)
		7, 10, 15	231	(2,038)
		20, 25, 30, 50	278	(2,453)
		70,100	261	(2,303)
Maximum Acceleration Output Torque ¹⁾ $T_{acc r}$	Nm (in-lb)	3, 4, 5, 7, 10, 15, 70, 100	282	(2,488)
		20, 25, 30, 50	347	(3,062)
Emergency Stop Output Torque ²⁾ $T_{em r}$	Nm (in-lb)	3, 4, 5, 7, 10, 15, 70, 100	656	(5,789)
		20, 25, 30, 50	900	(7,055)
Nominal Input Speed $N_{nom r}$	RPM	3,4,5	2000	
		7, 10, 15	2500	
		20, 25, 30, 50	3000	
		70,100	3500	
Maximum Input Speed $N_{max r}$	RPM	3 – 100	3800	
Standard Backlash ³⁾	arc-min	3 – 10	8	
		15 – 100	10	
Low Backlash ³⁾	arc-min	3 – 10	6	
		15 – 100	8	
Efficiency at Nominal Torque	%	3 – 10	96	
		15 – 100	93	
Noise Level at 3000 RPM ⁴⁾	db	3 – 100	66	
Torsional Stiffness	Nm/arc-min (in-lb/arc-min)	3 – 100	39	(345)
Maximum Allowable Case Temperature	° C	3 – 100	-20 to 90	
Degree of Protection			IP65	
Maximum Weight	kg (lbs)	3 – 10	14	(30)
		15 – 100	20	(43)

1) Parker MotionSizer sizing software available for free download at parkermotion.com.

2) Maximum of 1,000 stops

3) Measured at 2% of rated torque

4) Measured at 1 meter

PX Output Shaft Load Rating

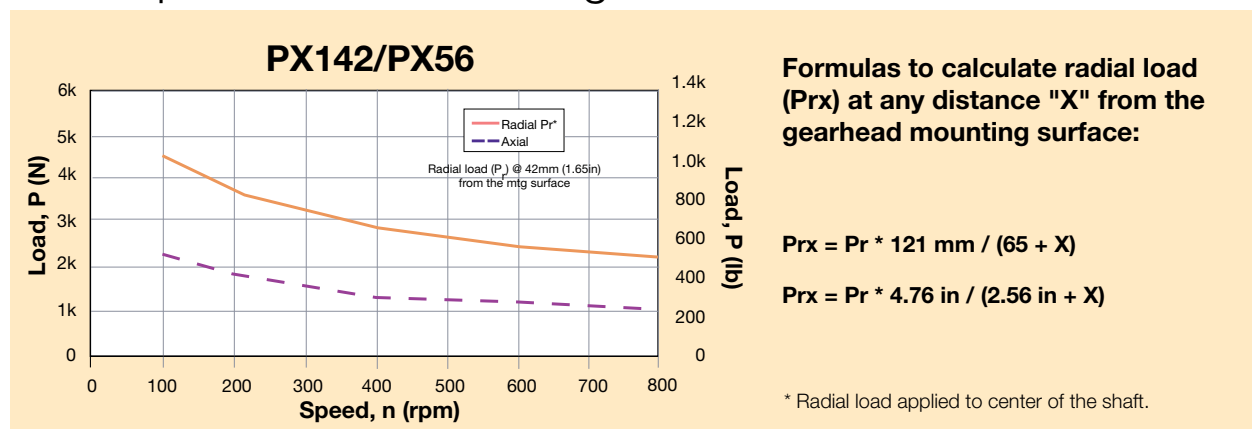

PX Dimensions

Free 3D Solid Models and drawings available at parkermotion.com

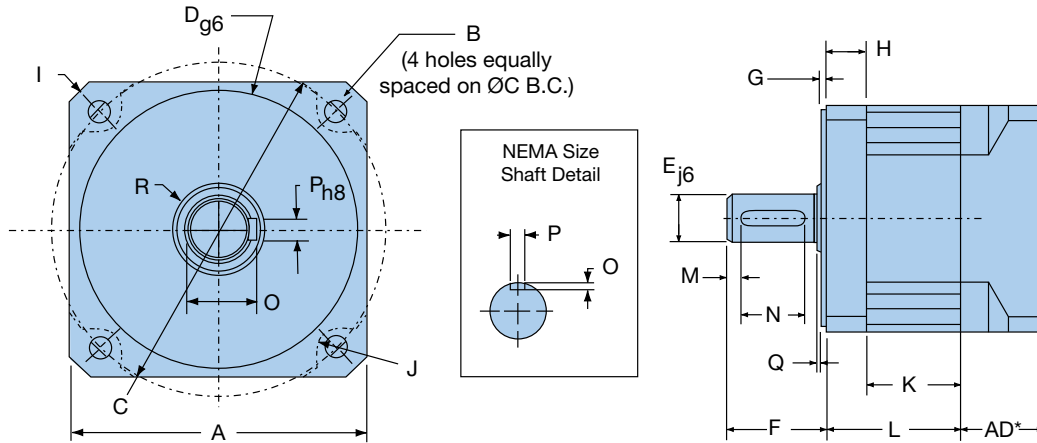

*AD=Adapter Length. Adapter will vary, depending on motor. (Visit our website or consult the factory for details.)

Metric Frame Size

Frame Size	A		B		C		D		E		F		G		H		I		J	
	Square Flange		Bolt Hole		Bolt Circle		Pilot Diameter		Output Shaft Diameter		Output Shaft Length		Pilot Thickness		Flange Thickness		Housing Diameter		Housing Recess	
	mm	in	mm	in	mm	in	mm	in	mm	in	mm	in	mm	in	mm	in	mm	in	mm	in
PX142	142	5.591	11.0	0.433	165	6.496	130	5.118	40	1.575	80	3.150	3.5	0.138	25	0.984	194	7.637	10.0	0.394

Frame Size	K1		K2		L1		L2		M		N		O		P		Q		R	
	Recess Length (for ratios 3-10)		Recess Length (for ratios 15-100)		Length (for ratios 3-10)		Length (for ratios 15-100)		Distance from Shaft End		Keyway Length		Key Height		Keyway Width		Shoulder Height		Shoulder Diameter	
	mm	in	mm	in	mm	in	mm	in	mm	in	mm	in	mm	in	mm	in	mm	in	mm	in
PX142	61.5	2.421	123.0	4.843	86.5	3.406	148.0	5.827	8	0.315	63	2.480	43.0	1.693	12	0.472	1.5	0.059	46	1.811

NEMA Frame Size

Frame Size	B		C		D		E		F		N		O		P	
	Bolt Hole		Bolt Circle		Pilot Diameter		Output Shaft Diameter		Output Shaft Length		Keyway Flat Length		Keyway Flat Depth		Keyway Flat Width	
	in	mm	in	mm	in	mm	in	mm	in	mm	in	mm	in	mm	in	mm
PX56	0.398	10.109	7.000	177.8	4.500	114.30	1.000	25.40	2.000	50.80	1.625	41.275	0.142	3.607	0.250	6.35

NOTE: NEMA size has 20% lower torque/stiffness ratings due to smaller output shaft diameter.

PX Inertia

All moment of inertia values are as reflected at the input of the gearhead

Frame Size	Units	Ratio					
		3	4, 5	7, 10	15	20, 25	30, 50, 70, 100
PX142	gm-cm-sec ²	8.826	4.514	3.326	4.849	5.179	2.840
PX56	oz-in-sec ²	0.124	0.063	0.047	0.068	0.073	0.040

Generation I Stealth® Series

RS Performance Specifications

Parameter	Units	Ratio	RS180		RS220	
Nominal Output Torque $T_{nom r}$	Nm (in-lb)	5	316	(2800)	678	(16,000)
		10	621	(5500)	1299	(11,500)
		15,20,25	938	(8300)	1808	(16,000)
		30,40,50,100	836	(7400)	1469	(13,000)
Maximum Acceleration Output Torque ¹⁾ $T_{acc r}$	Nm (in-lb)	5	373	(3300)	902	(7,100)
		10	734	(6500)	1582	(14,000)
		15,20,25, 30,40,50,100	1096	(9700)	2000	(17,700)
		5	870	(7700)	1853	(16,400)
Emergency Stop Output Torque ²⁾ $T_{em r}$	Nm (in-lb)	10	1695	(15,000)	3684	(32,600)
		15,20,25, 30,40,50,100	2520	(22,300)	4588	(40,600)
		5,10	1600		1200	
		5,20, 25,30,40	2000		1500	
Nominal Input Speed $N_{nom r}$	RPM	50,100	2400		1800	
		5 – 100	3000		2300	
Maximum Input Speed $N_{max r}$	RPM	5 – 100	3000		2300	
Standard Backlash ³⁾	arc-min	5 – 10	10		10	
		15 – 100	8		8	
Low Backlash ³⁾	arc-min	5 – 10	6		6	
		15 – 100	4		4	
Efficiency at Nominal Torque	%	5 – 100	94		94	
Noise Level at: 1500 RPM ⁴⁾ 2000 RPM ⁴⁾ 3000 RPM ⁴⁾	db	5 – 100	—		—	
			72		—	
			—		72	
Torsional Stiffness	Nm/arc-min (in-lb/arc-min)	5 – 100	90	(800)	170	(1,500)
Maximum Allowable Case Temperature	° C	5 – 100	-20 to 90			
Degree of Protection		IP65				
Maximum Weight	kg (lbs)	5 – 100	43	(94)	80	(177)

1) Parker MotionSizer sizing software available for free download at parkermotion.com.

2) Maximum of 1,000 stops

3) Measured at 2% of rated torque

4) Measured at 1 meter.

RS Output Shaft Load Rating

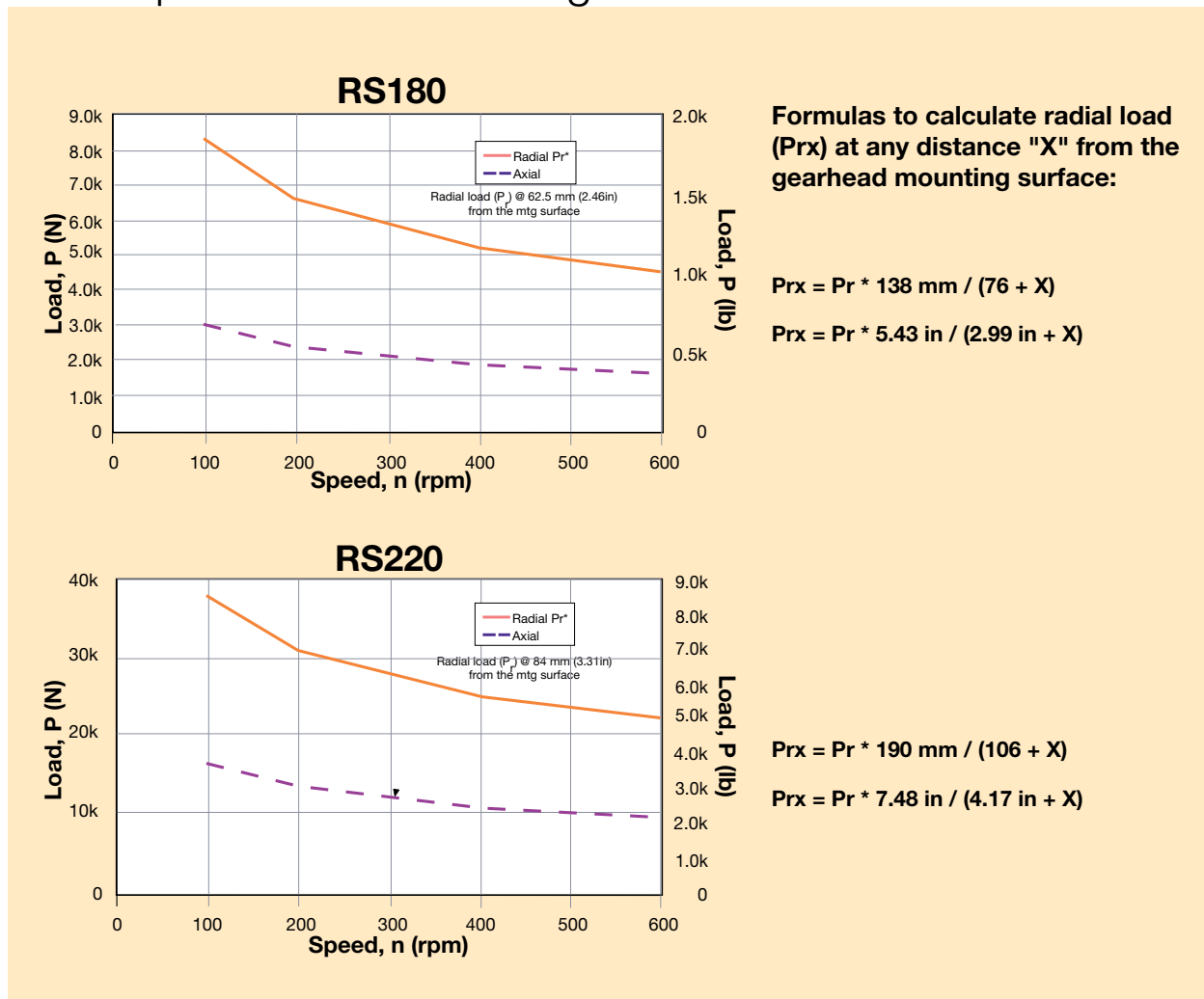

* Radial load applied to center of the shaft.

RS Inertia

All moment of inertia values are as reflected at the input of the gearhead

Ratio	Units	Frame Size	
		RS180	RS220
5	gm-cm-sec ²	26.5	82.2
	oz-in-sec ²	0.368	1.14
10	gm-cm-sec ²	16.7	50.4
	oz-in-sec ²	0.232	0.700
15, 30	gm-cm-sec ²	15.2	47.4
	oz-in-sec ²	0.211	0.658
20, 25, 40	gm-cm-sec ²	10.7	34.3
	oz-in-sec ²	0.149	0.476
50, 100	gm-cm-sec ²	6.70	21.2
	oz-in-sec ²	0.093	0.294

Generation I Stealth® Series

RS Dimensions

Free 3D Solid Models and drawings available at parkermotion.com

*AD=Adapter Length. Adapter will vary, depending on motor.
(Visit our website or consult the factory for details.)

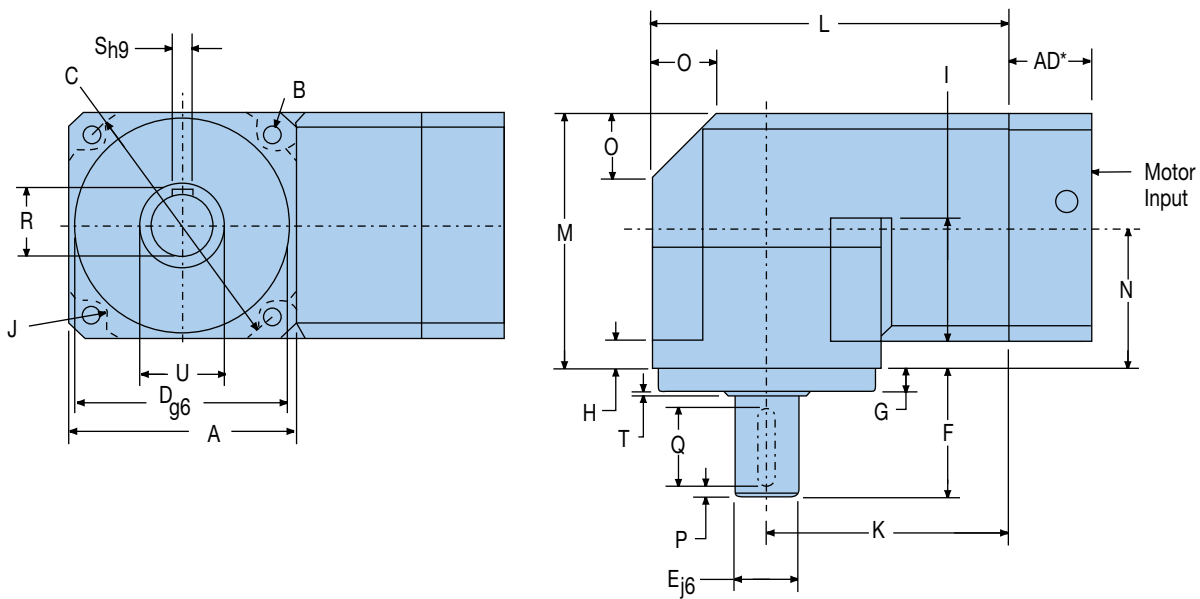

Metric Frame Sizes

Frame Size	A		B		C		D		E		F		G	
	Square Flange		Bolt Hole		Bolt Circle		Pilot Diameter		Output Shaft Diameter		Output Shaft Length		Pilot Thickness	
	mm	in	mm	in	mm	in	mm	in	mm	in	mm	in	mm	in
RS180	182	7.165	13	0.512	215	8.465	160	6.299	55	2.165	105	4.134	20	0.787
RS220	220	8.661	17	0.669	250	9.843	180	7.087	75	2.953	138	5.433	30	1.181

Frame Size	H		I		J		K		L		M		N	
	Flange Thickness		Recess Length		Housing Recess		Distance to Output Centerline		Housing Length		Housing Width		Distance to Input Centerline	
	mm	in	mm	in	mm	in	mm	in	mm	in	mm	in	mm	in
RS180	16	0.630	97.5	3.839	16	0.630	172	6.772	263	10.354	197	7.756	106	4.173
RS220	22	0.866	101	3.976	16	0.630	230	9.055	340	13.386	245	9.646	135	5.315

Frame Size	O		P		Q		R		S		T		U	
	Taper Distance		Distance from Shaft End		Keyway Length		Key Height		Keyway Width		Shoulder Height		Shoulder Diameter	
	mm	in	mm	in	mm	in	mm	in	mm	in	mm	in	mm	in
RS180	55	2.165	6	0.236	70	2.756	59	2.323	16	0.630	3	0.118	70	2.756
RS220	60	2.362	6	0.236	90	3.543	79.5	3.130	20	0.787	3	0.118	95	3.740

Generation I Stealth® Series

Stealth® How to Order

Choose gearhead series, frame size, ratio, backlash and orientation from the chart below.

Gearhead Ordering Information

Order Example:				
①	②	③	④	⑤
PS	180	- 003	- XXX	- S H
Series	Frame Size	Ratio	Backlash	Orientation
PS	180 (Metric) 220 (Metric)	003, 004, 005, 007, 010, 015, 020, 025, 030, 040, 050, 070, 100	S = Standard L = Low	See illustrations below H = Horizontal orientation U = Output shaft pointing up D = Output shaft pointing down
PX	142 (Metric) 56 (NEMA)	003, 004, 005, 007, 010, 015, 020, 025, 030, 050, 070, 100	Blank = Standard LB = Low	—
RS	180 (Metric) 220 (Metric)	005, 010, 015, 020, 025, 030, 040, 050, 100	S = Standard L = Low	See illustrations below H = Horizontal orientation U = Output shaft pointing up D = Output shaft pointing down E = Motor input facing up F = Motor input facing down

Recommended Parker Motor and Mounting Kit

Frame Size	Recommended Servo Motor		
	Motor	Mounting Kit	AD Dimension
PS180	MPP142	MT180-131	67.5 mm
	MPP180	MT180-096	109 mm
PS220	MPP180	MT220-021	104 mm
	MPP230	MT220-022	138 mm
PX142	MPP115	MX142-107	70 mm
	MPP142	MX142-008	75 mm
RS180	MPP142	MZ180-025	80 mm
	MPP190	MZ180-032	120 mm
RS220	MPP190	MZ220-009	108 mm
	MPP230	Consult Factory	—

Sizing/Selection Design Assistance

To properly size and select a gearhead for a specific application requires consideration of several interrelated parameters including: speed, continuous torque, repetitive peak torque or acceleration torque, emergency stop torque, duty cycle, ambient temperature and radial and axial shaft load.

The 9 step procedure on pages 72-73 provides a straightforward method of selecting the correct gearhead for your application.

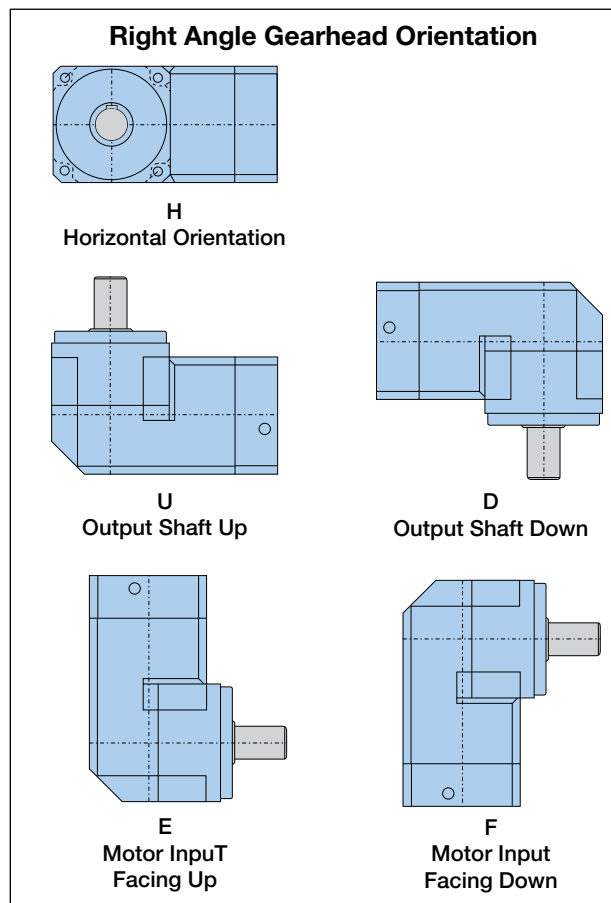

PV Series Gearheads

PV Series: Value Alternative Precision Planetary Gearheads

PV = Power + Versatility

The PV Series planetary gearhead combines power and versatility in an economical package. It comes in a wide range of options, including dimensional output face crossovers to the Parker PX, Alpha LP, Neugart PLE, Stober PE and standard NEMA gearheads.

The PV Series is available in metric or NEMA frame sizes: 40, 60, 90 and 115 mm, and NEMA sizes 17, 23, 34 and 42. Ratios are available from 3:1 to 100:1.

Whether you're an OEM or an end user searching for competitive alternatives, the PV offers a superior solution. Parker's PV Series gearheads are made in the USA.



- **Higher radial load capacity: Taper roller output bearings**
- **Competitive Alternatives: Five Drop-In Output Face Options**
- **Universal mounting kits: Quicker deliveries and easier mounting**
- **Higher gear wear resistance: Plasma Nitriding heat treating**

PV Series Precision Gearheads

Product Series	Gear Geometry	Configuration	Frame Size (mm)	Nominal Continuous Torque (Nm)	Radial Load (N)	Backlash arc-min	IP Rating
PV40/17	Planetary	In-Line	40 (NEMA 17)	3.5 – 6.7	190 – 590	<15	IP64
PV60/23	Planetary	In-Line	60 (NEMA 23)	10.2 – 22.5	665 – 2535	<12	IP64
PV90/34	Planetary	In-Line	90 (NEMA 34)	33 – 71	1040 – 4270	<10	IP64
PV115/42	Planetary	In-Line	115 (NEMA 42)	67 – 144	1235 – 10,550	<8	IP64

PV Series Gearhead Features and Benefits

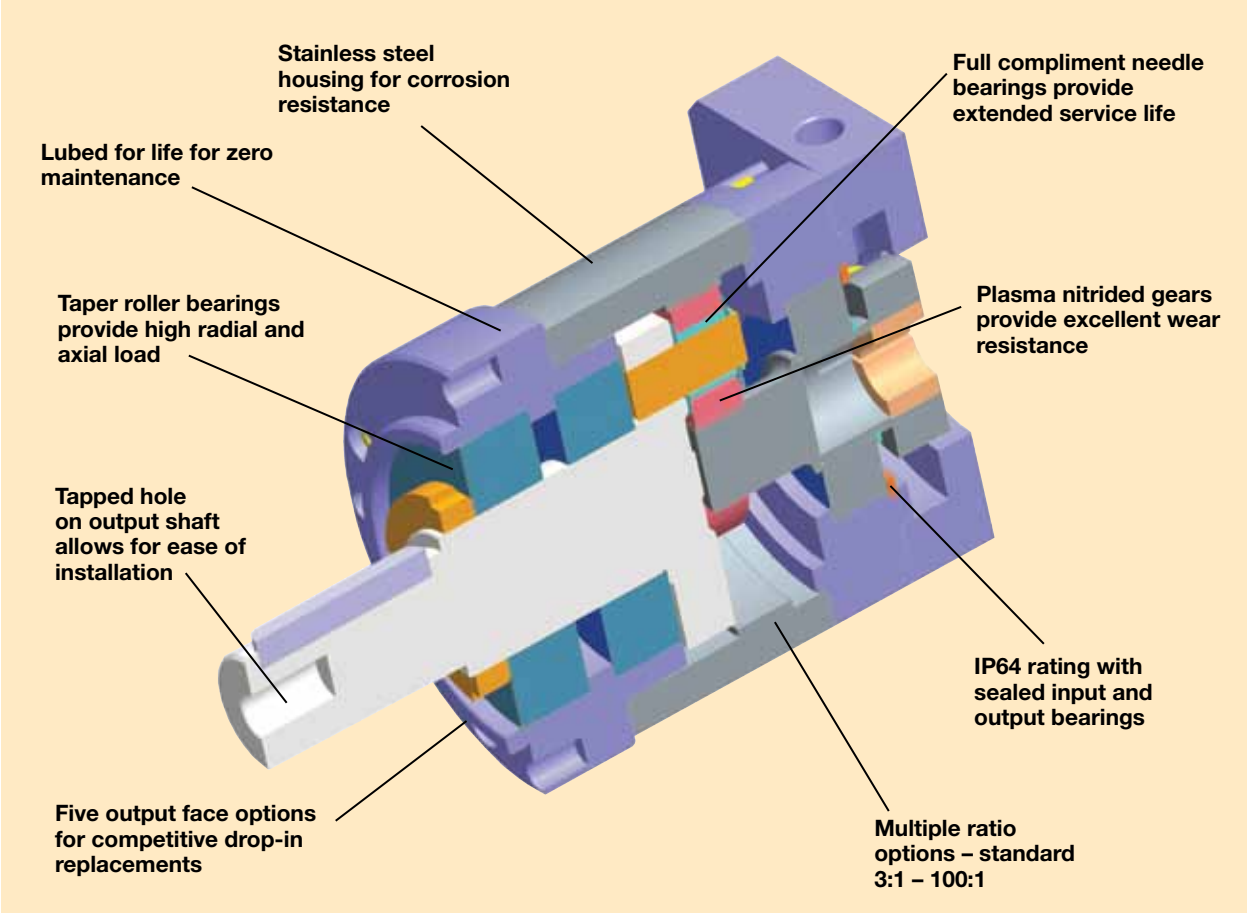

PV Series Gearheads

Performance Specifications

Parameter	Units	Ratio	PV40/PV17	PV60/PV23	PV90/PV34	PV115/PV42		
Nominal Output Torque $T_{nom r}$	Nm (in-lb)	3	–	–	12.0 (106.200)	35 (309.75)	74 (654.90)	
		4	5.9 (52.215)	18.9 (167.265)	56 (495.60)	111 (982.30)		
		5	6.2 (54.870)	19.6 (173.460)	58 (513.30)	115 (1017.70)		
		7	5.5 (48.675)	16.7 (147.795)	52 (460.20)	104 (920.40)		
		10	3.5 (30.975)	10.6 (93.810)	33 (292.05)	67 (592.95)		
		12	–	–	18.2 (161.070)	54 (477.90)	112 (991.20)	
		15	–	–	19.4 (171.690)	58 (513.30)	120 (1062.00)	
		16	6.5 (57.525)	–	–	–	–	–
		20	6.5 (57.525)	21.5 (190.275)	67 (592.95)	136 (1203.60)		
		25	6.7 (59.295)	20.0 (177.000)	63 (557.55)	126 (1115.10)		
		30	–	–	22.5 (199.275)	71 (628.35)	144 (1274.40)	
		35	6.7 (59.295)	–	–	–	–	–
		40	6.5 (57.525)	21.5 (190.275)	67 (592.95)	136 (1203.60)		
		50	6.7 (59.295)	20.0 (177.000)	63 (557.55)	126 (1115.10)		
		70	5.5 (48.675)	16.7 (147.795)	52 (460.20)	104 (920.40)		
100	3.5 (30.975)	10.6 (93.810)	33 (292.05)	67 (592.95)				
Maximum Acceleration Output Torque ¹⁾ $T_{acc r}$	Nm (in-lb)	3	–	–	24.0 (212.400)	70 (619.50)	148 (1309.80)	
		4,5,12,15	11.8 (104.430)	36.4 (322.140)	108 (955.80)	222 (1964.70)		
		7,70	11.0 (97.350)	33.4 (295.590)	104 (920.40)	208 (1840.80)		
		10,100	7.0 (61.950)	21.2 (187.620)	66 (584.10)	134 (1185.90)		
		16,20,25,30,35,40,50	13.0 (115.050)	40.0 (354.000)	126 (1115.10)	252 (2230.20)		
Emergency Stop Output Torque ²⁾ $T_{em r}$	Nm (in-lb)	3,4,5,12,15,16,20,25,30,35,40,50	16.0 (141.600)	55.0 (486.750)	170 (1504.50)	350 (3097.50)		
		7, 70	13.7 (121.245)	44.0 (389.400)	137 (1212.45)	290 (2466.50)		
		10, 100	9.2 (81.420)	39.0 (345.150)	122 (1079.70)	255 (2256.75)		
Nominal Input Speed $N_{nom r}$	RPM	3 – 100	4500	4000	3500	3000		
Maximum Input Speed $N_{max r}$	RPM	3 – 100	8000	6000	6000	5000		
Service Life	h	3 – 100	20,000					
Standard Backlash ³⁾	arc-min	3 – 10	<15	<12	<10	<8		
		15 – 100	<18	<16	<14	<12		
Efficiency at Nominal Torque	%	3 – 10	96					
		15 – 100	94					
Noise Level at 3000 RPM ⁴⁾	db	3 – 100	<60	<65	<65	<70		
Maximum Allowable Case Temperature	° C	3 – 100	-20 to 100					
Lubrication		3 – 100	Lifetime lubrication					
Mounting Position		3 – 100	Any					
Direction of Rotation		3 – 100	Same as Input					
Degree of Protection		3 – 100	IP64					
Maximum Weight	kg (lbs)	3 – 10	0.6 (1.2)	1.2 (2.5)	3.2 (7.0)	6.8 (13.5)		
		15 – 100	0.9 (2.0)	1.6 (3.5)	4.3 (9.5)	9.7 (19.3)		

1) Parker MotionSizer sizing software available for free download at parkermotion.com. $t_{acc} + t_{dec} = 0.2$ ($t_{acc} + t_{cont} + t_{dec}$) $T_{cont} = 0.25 T_{acc}$

2) Maximum of 1000 stops.

3) Measured at 2% of rated torque.

4) Measure at 1m.

Inertia

All moment of inertia values are as reflected at the input of the gearhead

Ratio	Units*	PV40/PV17	PV60/PV23	PV90/PV34	PV115/PV42
3	kg-cm ²	–	0.1400	0.7400	1.9700
	in-lb-sec ²	–	0.000124	0.000655	0.001743
4	kg-cm ²	0.0200	0.1000	0.5000	1.3400
	in-lb-sec ²	0.000018	0.000089	0.000443	0.001186
5	kg-cm ²	0.0180	0.0840	0.3900	1.1300
	in-lb-sec ²	0.000016	0.000074	0.000345	0.001000
7	kg-cm ²	0.0160	0.0750	0.3400	0.9300
	in-lb-sec ²	0.000014	0.000066	0.000301	0.000823
10	kg-cm ²	0.0160	0.0700	0.3000	0.8500
	in-lb-sec ²	0.000014	0.000062	0.000266	0.000752
12	kg-cm ²	–	0.0970	0.4900	1.2300
	in-lb-sec ²	–	0.000086	0.000434	0.001089
15	kg-cm ²	–	0.0830	0.3900	1.0400
	in-lb-sec ²	–	0.000073	0.000345	0.000920
16	kg-cm ²	0.0190	–	–	–
	in-lb-sec ²	0.000017	–	–	–
20	kg-cm ²	0.0170	0.0830	0.3900	1.0400
	in-lb-sec ²	0.000015	0.000073	0.000345	0.000920
25	kg-cm ²	0.0170	0.0830	0.3900	1.0400
	in-lb-sec ²	0.000015	0.000073	0.000345	0.000920
30	kg-cm ²	–	0.0700	0.3000	0.8400
	in-lb-sec ²	–	0.000062	0.000266	0.000743
35	kg-cm ²	0.0160	–	–	–
	in-lb-sec ²	0.000014	–	–	–
40, 50, 70, 100	kg-cm ²	0.0160	0.0700	0.3000	0.8400
	in-lb-sec ²	0.000014	0.000062	0.000266	0.000743

* Note: 1 kg-cm² = 0.000885 in-lb-sec²

Maximum Output Shaft Load Rating

See load rating charts on pages 44-45

Output Face Option*		PV40/PV17	PV60/PV23	PV90/PV34	PV115/PV42
Maximum Radial Load Pr, N ** (3-100 ratios)	FE	200	665	1040	1235
	TN	440	665	1040	2100
	FB, FN, TA	590	2535	4270	8550
Maximum Axial Load Pr, N ** (3-100 ratios)	FE	190	765	1140	1300
	TN	430	765	1140	2380
	FB, FN, TA	530	2350	4670	10550

* See How to Order page 48, items 3 & 4 for front face/output face code definitions.

** @100 rpm, radial load applied at center of shaft

PV Series Gearheads

Output Shaft Load Ratings – PV40/PV17 & PV60/PV23

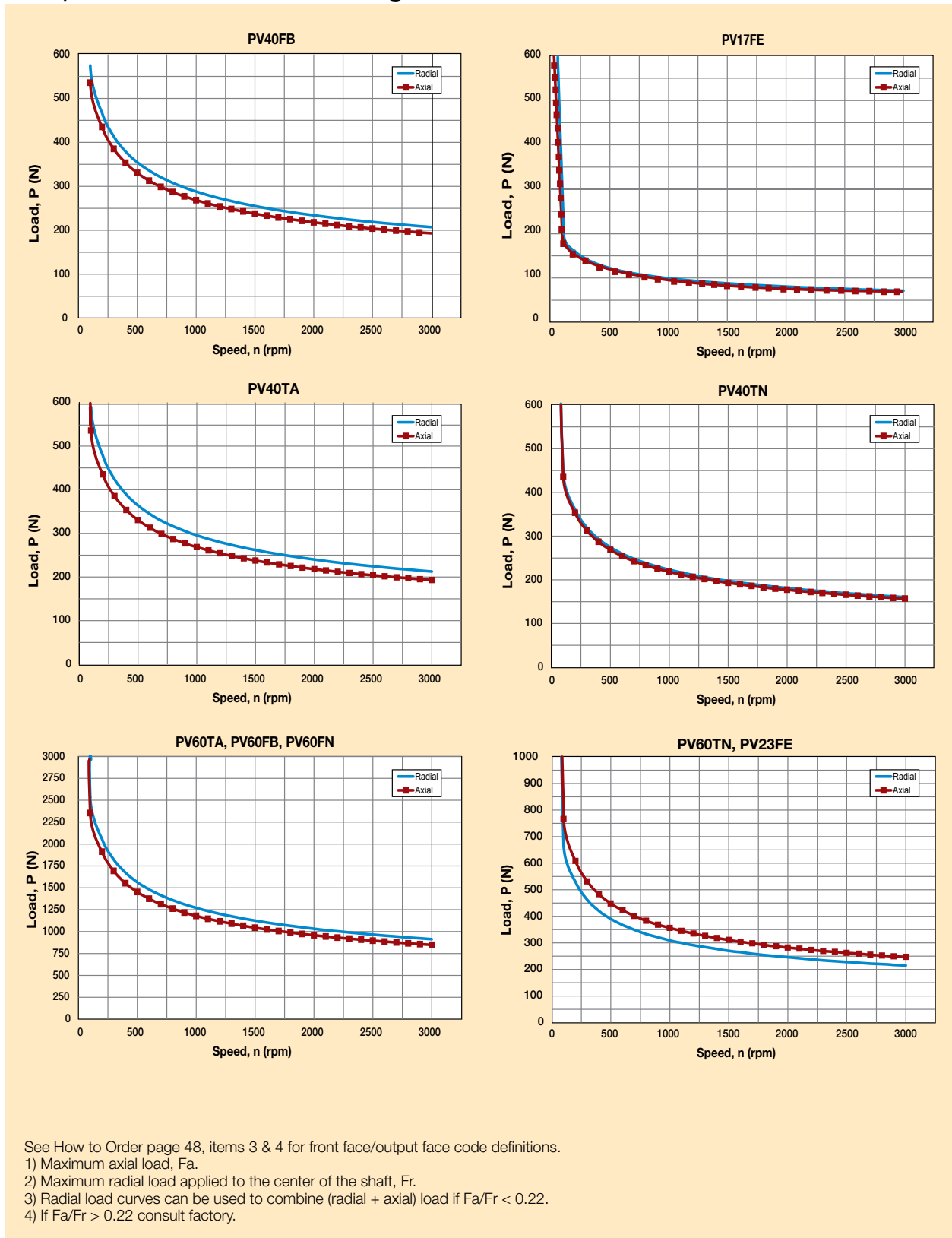

Output Shaft Load Ratings – PV90/PV34 & PV115/PV42

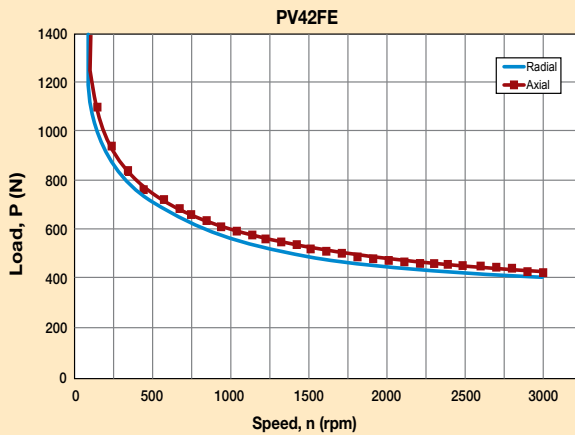
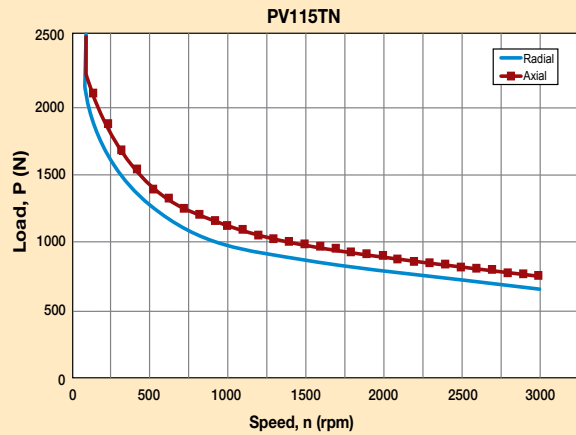
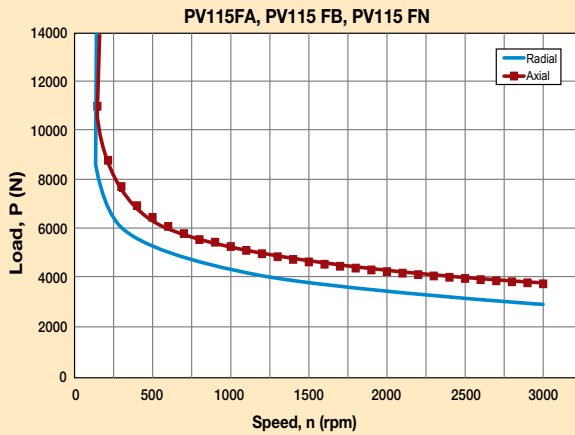
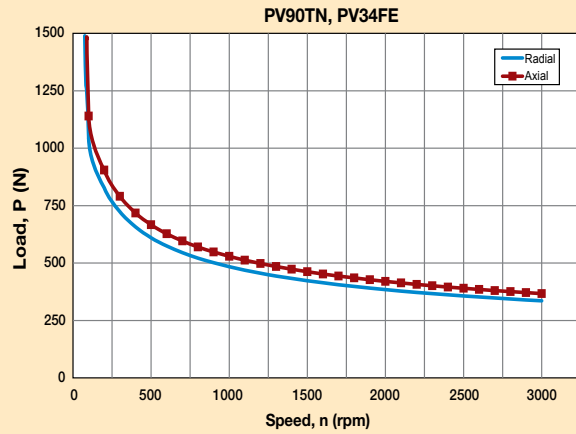
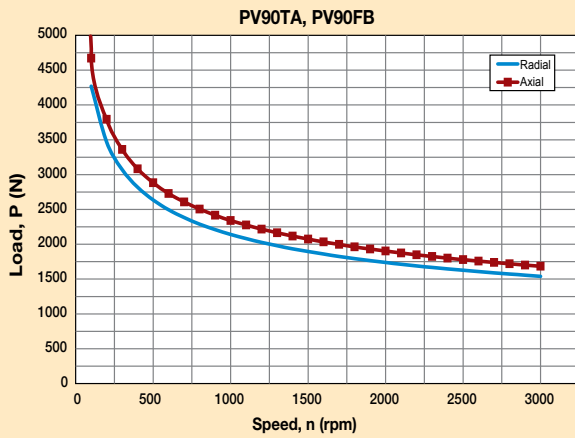

See How to Order page 48, items 3 & 4 for front face/output face code definitions.

- 1) Maximum axial load, F_a .
- 2) Maximum radial load applied to the center of the shaft, F_r .
- 3) Radial load curves can be used to combine (radial + axial) load if $F_a/F_r < 0.22$.
- 4) If $F_a/F_r > 0.22$ consult factory.

PV Series Gearheads

Dimensions – Tapped Face (TA & TN)

Free 3D Solid Models and drawings available at parkermotion.com

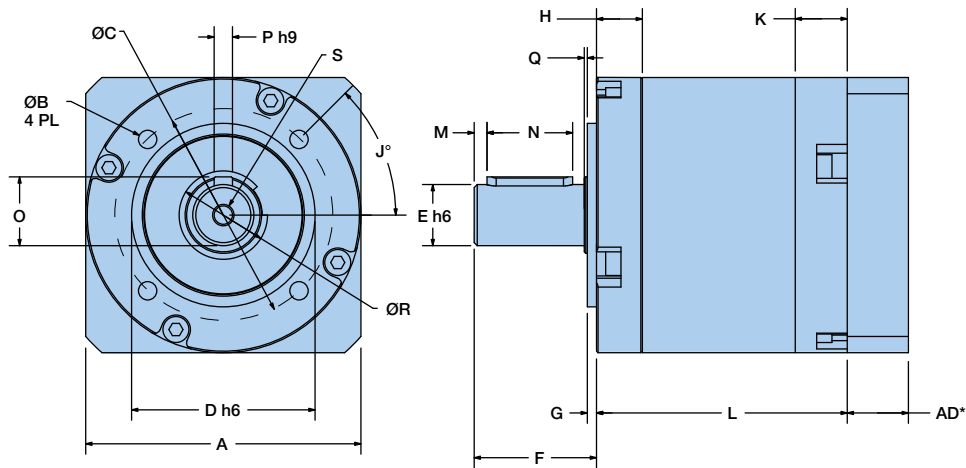

*AD = Adapter length. See how to order page for mounting kit adapter lengths.

Metric Frame Sizes

Frame Size	A		B		C		D		E		F		G		H		J	K	
	Body Diameter		Tap x Depth		Bolt Circle		Pilot Diameter		Output Shaft Diameter		Output Shaft Length		Pilot Thickness		Flange Thickness		Lead Angle	Rear Thickness	
	mm	in	mm	in	mm	in	mm	in	mm	in	mm	in	mm	in	mm	in	°	mm	in
PV40TN	43	1.693	M4x7	34	1.339	26	1.024	10	0.394	26	1.024	1.5	0.059	10	0.394	45	11	0.433	
PV40TA	50	1.969	M4x10	44	1.732	35	1.378	12	0.472	25	0.984	3	0.118	10	0.394	90	11	0.433	
PV60TN	62	2.441	M5x10	52	2.047	40	1.575	14	0.551	35	1.378	2.5	0.098	12	0.472	45	16	0.630	
PV60TA	70	2.756	M5x10	62	2.362	52	2.047	16	0.630	36	1.417	5	0.197	16	0.630	90	16	0.630	
PV90TN	90	3.543	M6x11	70	2.756	60	2.362	20	0.787	40	1.575	3	0.118	15	0.591	45	17	0.670	
PV90TA	90	3.543	M6x12	80	3.150	68	2.677	22	0.866	46	1.811	5	0.197	18.5	0.728	90	17	0.670	
PV115TN	115	4.528	M10x16	100	3.937	80	3.150	25	0.984	55	2.165	4	0.157	20	0.787	45	23	0.906	
PV115TA	120	4.724	M8x20	108	4.252	90	3.543	32	1.260	70	2.756	6	0.236	28	1.102	90	23	0.906	

Frame Size	L1		L2		M		N		O		P		Q		R		S
	Length (3 - 10 Ratios)		Length (12 - 100 Ratios)		Distance from Shaft End		Keyway Length		Key Height		Keyway Width		Shoulder Height		Shoulder Diameter		Tap & Depth (end of shaft)
	mm	in	mm	in	mm	in	mm	in	mm	in	mm	in	mm	in	mm	in	
PV40TN	48.5	1.909	63	2.480	3.1	0.122	16	0.630	10.2	0.402	3	0.118	0.6	0.024	11.633	0.458	M3x6
PV40TA	48.5	1.909	63	2.480	1.3	0.051	16	0.630	13.5	0.531	4	0.157	3.5	0.138	17.831	0.702	M4x8
PV60TN	63	2.480	83	3.268	2.71	0.107	25	0.984	16		5	0.197	2.5	0.098	19.939	0.785	M5x12
PV60TA	67	2.638	87	3.425	2.21	0.087	25	0.984	18	0.709	5	0.197	3	0.118	28	1.102	M5x12
PV90TN	82	3.228	105.5	4.154	4.197	0.165	28	1.102	22.5	0.886	6	0.236	1	0.039	25	0.984	M6x12
PV90TA	85.5	3.366	109	4.291	3.197	0.126	28	1.102	24.5	0.965	6	0.236	5	0.197	38	1.496	M8x13
PV115TN	102	4.016	136	5.354	5.2	0.205	40	1.575	28	1.102	8	0.315	1	0.039	35	1.378	M10x20
PV115TA	110	4.331	144	5.669	4	0.157	50	1.969	35	1.378	10	0.394	1.8	0.071	40	1.575	M12x22

Dimensions – Flange Face (FB, FE & FN)

Free 3D Solid Models and drawings available at parkermotion.com

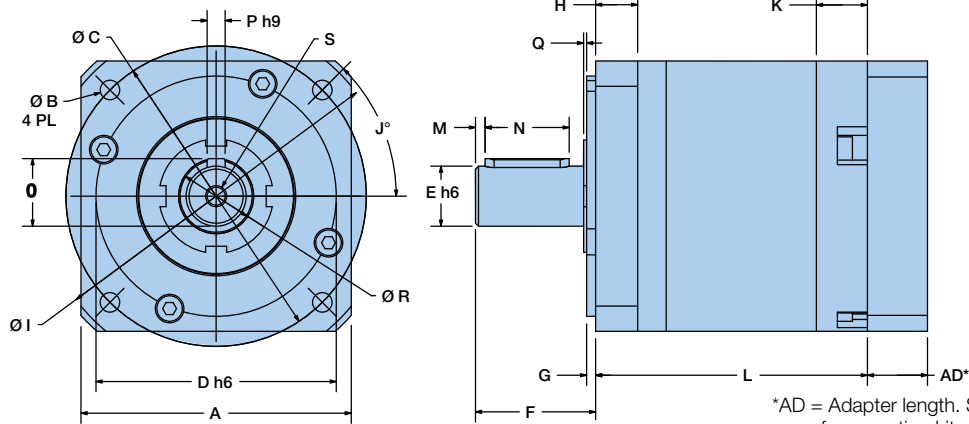

*AD = Adapter length. See how to order page for mounting kit adapter lengths.

Metric & NEMA Frame Sizes

Frame Size	A		B		C		D		E		F		G		H		I		J
	Body Diameter		Bolt Hole		Bolt Circle		Pilot Diameter		Output Shaft Diameter		Output Shaft Length		Pilot Thickness		Flange Thickness		Housing Diameter		Lead Angle
	mm	in	mm	in	mm	in	mm	in	mm	in	mm	in	mm	in	mm	in	mm	in	°
PV40FB	43	1.693	3.4	0.134	50	1.969	35	1.378	13	0.512	26	1.024	3	0.118	10	0.394	56	2.205	45
PV60FB	62	2.441	5.5	0.217	70	2.756	50	1.969	16	0.630	25	0.984	2.5	0.098	10.3	0.406	80	3.150	45
PV60FN	62	2.441	5.5	0.217	70	2.756	50	1.969	14	0.551	25	0.984	2.5	0.098	10.3	0.406	80	3.150	45
PV90FB	90	3.543	6.5	0.256	100	3.937	80	3.150	20	0.787	40	1.575	3	0.118	14	0.551	116	4.567	45
PV90FN	90	3.543	6.5	0.256	100	3.937	80	3.150	20	0.787	40	1.575	3	0.118	14	0.551	116	4.567	45
PV115FB	115	4.528	8.5	0.335	130	5.118	110	4.331	24	0.945	50	1.969	3.5	0.138	18	0.709	152	5.984	45
PV115FN	115	4.528	8.5	0.335	130	5.118	110	4.331	25	0.984	55	2.165	3.5	0.138	18	0.709	152	5.984	45

Frame Size	K		L1		L2		M		N		O		P		Q		R		S
	mm	in	mm	in	mm	in	mm	in	mm	in	mm	in	mm	in	mm	in	mm	in	°
PV17FE	1.693	43	0.138	3.5	1.724	43.8	0.866	22	0.250	6.35	0.984	25	0.059	1.5	0.236	6	2.165	55	45
PV23FE	2.441	62	0.195	4.95	2.625	66.675	1.500	38.1	0.375	9.525	1.000	25.4	0.098	2.5	0.374	9.5	3.150	80	45
PV34FE	3.543	90	0.217	5.52	3.875	98.43	2.875	73.025	0.500	12.7	1.250	31.75	0.118	3	0.591	15	4.567	116	45
PV42FE	4.528	115	0.281	7.14	4.949	125.7	2.187	55.55	0.625	15.875	1.500	38.1	0.094	2.4	0.787	20	5.984	152	45

Frame Size	K		L1		L2		M		N		O		P		Q		R		S
	Rear Thickness		Length (3 – 10 Ratios)		Length (12 – 100 Ratios)		Distance from Shaft End		Keyway Length		Key Height		Keyway Width		Shoulder Height		Shoulder Diameter		Tap & Depth
	mm	in	mm	in	mm	in	mm	in	mm	in	mm	in	mm	in	mm	in	mm	in	
PV40FB	11	0.433	48.5	1.909	63	2.480	2.1	0.083	16	0.630	15	0.591	5	0.197	2	0.079	17.831	0.702	M4x8
PV60FB	16	0.630	71.5	2.815	91.5	3.602	3.2	0.126	16	0.630	18	0.709	5	0.197	1	0.039	28	1.102	M5x12
PV60FN	16	0.630	71.5	2.815	91.5	3.602	3.2	0.126	16	0.630	16	0.630	5	0.197	1	0.039	28	1.102	M5x12
PV90FB	17	0.670	90.5	3.563	119	4.685	3.197	0.126	28	1.102	22.5	0.886	6	0.236	1	0.039	38	1.496	M6x12
PV115FB	23	0.906	114.5	4.508	148.5	5.846	4.2	0.165	40	1.575	27	1.063	8	0.315	1.5	0.059	40	1.575	M10x22
PV115FN	23	0.906	114.5	4.508	148.5	5.846	4.2	0.165	40	1.575	27	1.063	8	0.315	1.5	0.059	40	1.575	M10x22

Frame Size	K		L1		L2		M		N		O		P		Q		R		S
	mm	in	mm	in	mm	in	mm	in	mm	in	mm	in	mm	in	mm	in	mm	in	
PV17FE	0.433	11	1.909	48.5	2.480	63	-	-	-	-	-	-	-	-	0.091	2.3	0.458	11.633	-
PV23FE	0.630	16	2.382	60.5	3.169	80.5	-	-	0.748	19	0.372	9.444	Flat	0.039	1	0.785	19.939	M5x12	
PV34FE	0.670	17	3.228	82	4.154	105.5	-	-	1.063	27	0.561	14.247	0.125	3.175	0.039	1	0.984	25	M6x12
PV42FE	0.906	23	4.016	102	5.354	136	0.016	0.4	1.120	28.450	0.705	17.91	0.188	4.775	-	-	-	-	M6x20

PV Series Gearheads

How to Order

Use the tables below to configure your PV gearhead and motor mounting kit part number.

	①	②	③	④	⑤
Order Example:	PV	40	T	N	- 004

Sizing/Selection Design Assistance

To properly size and select a gearhead for a specific application requires consideration of several interrelated parameters including: speed, continuous torque, repetitive peak torque or acceleration torque, emergency stop torque, duty cycle, ambient temperature and radial and axial shaft load.

The 9 step procedure on pages 72-73 provides a straightforward method of selecting the correct gearhead for your application.

①	②		③		④		⑤		
Series	Frame Size		Front Face		Output Face Compatible		Ratio		
PV Power Versatility Series	40	40 mm	T	Tapped (round)	A	Alpha/Stober	004	4:1	
			N		N	Neugart	005	5:1	
			F	Flanged (square)	B	Parker Bayside (PX)	007	7:1	
	17	NEMA 17	F	Flanged (square)	E	NEMA (English)	010	10:1	
							016	16:1	
							020	20:1	
							025	25:1	
							035	35:1	
							040	40:1	
	050	50:1							
	070	70:1							
	100	100:1							
	60	60 mm	T	Tapped (round)	A	Alpha/Stober	003	3:1	
			N		N	Neugart	004	4:1	
			F	Flanged (square)	B	Parker Bayside (PX)	005	5:1	
	23	NEMA 23	F	Flanged (square)	E	NEMA (English)	007	7:1	
							010	10:1	
	90	90 mm	T	Tapped (round)	A	Alpha/Stober	012	12:1	
N							Neugart	015	15:1
F							Flanged (square)	B	Parker Bayside (PX)
34	NEMA 34	F	Flanged (square)	E	NEMA (English)	025	25:1		
						030	30:1		
						040	40:1		
115	115 mm	T	Tapped (round)	A	Alpha/Stober	050	50:1		
		N		N	Neugart	070	70:1		
		F	Flanged (square)	B	Parker Bayside (PX)	100	100:1		
42	NEMA 42	F	Flanged (square)	E	NEMA (English)				

Mounting Kit Ordering Information

Know your motor and need our mounting kit part number? Use the charts below or use our Motor Mounting Search Tool on our website at:

www.parkermotion.com

⑥	⑦	⑧
Order Example:		
⑥	⑦	⑧
Series	Frame Size	Factory Assigned
MV	40 40 or 17 60 60 or 23	See Motor Mounting Search Tool on parkermotion.com or consult factory for part number
(Mounting kit for PV)	90 90 or 34 115 115 or 42	

Mounting Kit Adapter Length*

Frame Size	Motor Shaft Length		"AD"	
	mm	(in)	mm	(in)
40/17	12 – 20	(0.472 – 0.787)	13.7	(0.539)
	20.1 – 25.4	(0.791 – 1.000)	19.0	(0.748)
60/23	16 – 25.4	(0.630 – 1.000)	16.5	(0.650)
	25.4 – 31.8	(1.004 – 1.252)	22.5	(0.886)
90/34	20 – 31.8	(0.787 – 1.252)	20.0	(0.787)
	31.9 – 40	(1.256 – 1.575)	28.5	(1.122)
115/42	22 – 40	(0.866 – 1.575)	24.0	(0.945)
	40.1 – 51	(1.579 – 2.008)	35.0	(1.378)

* Adapter length may vary depending on motor make and model.

Recommended Parker Motor and Mounting Kit*

Frame Size	Recommended Servo Motor			Recommended Stepper Motor		
	Motor	Mounting Kit	AD Dimension	Motor	Mounting Kit	AD Dimension
40 or 17	BE16	MV40-005	19 mm	LV17	MV40-003	19 mm
	SM16			HV17		
60 or 23	BE23	MV60-001 MV60-005	22.5 mm 16.5 mm	LV23	MV60-002	16.5 mm
	SM23			HV23		
90 or 34	BE34	MV90-005 MV90-002	20 mm 28.5 mm	LV34	MV90-005	20 mm
	MPP092			HV34		
115 or 42	MPP100	MV115-039 MV115-010	24 mm 35 mm			
	MPP115					

*Parker MotionSizer sizing software available for free download at: www.parkermotion.com

Stealth® MultiDrive Gearheads

Stealth® MultiDrive Series:
The Flexible Right Angle
Gearhead Solution



Stealth® MultiDrive (MD) offers three different output options for true flexibility. MultiDrive models include low-ratio, dual-shaft and hollow-shaft options in a compact, right angle package. MultiDrive gearheads features Stealth helical gearing for high torque, high accuracy and quiet operation. With five frame sizes and multiple ratios to choose from, you are sure to find a Stealth MultiDrive to fit your servo motor application.

- **Space Saving: Compact, right-angle design saves space in many applications**
- **Low Backlash: Standard as low as 8 arc-minutes and 4 arc-minutes optional**
- **Smooth, Quiet Operation and Long Life: Hardened, precision spiral bevel gears ensure quiet operation**
- **Quick, Error-Free Mounting to any servo or stepper motor using Parker's ServoMount® design**
- **Sealed Unit: Seals and O-rings provide IP65 protection to prevent leaks and to protect against harsh environments**

MultiDrive RT, RD and RB Series Precision Gearheads

Product Series	Configuration	Ratios	Gear Geometry	Performance	Frame Size (mm)	Continuous Torque Nm (in-lb)	Radial Load N (lbs)	Backlash arc-min
RT	Right Angle Hollow Shaft	3, 9, 15, 21 and 30:1	Helical	High Precision	90 – 220	23 – 565 (204 – 5178)	2800 – 7500 (692 – 1685)	<14 to <6
RD	Right Angle Double Shaft	1, 2, 3, 9, 15, 21 and 30:1	Helical	High Precision	90 – 220	30 – 150 (266 – 1328)	2800 – 7500 (692 – 1685)	<14 to <6
RB	Right Angle Low Ratio	1, 2 and 3:1	Helical	High Precision	90 – 220	35 – 190 (266 – 1682)	2800 – 7500 (692 – 1685)	<14 to <6

Performance Specifications

		Frame Size (RT, RD, RB)					
		Ratio	R_90	R_115	R_142	R_180	R_220
Nominal Output Torque $T_{nom r}$	Nm (in-lb)	1	23 (200)	45 (400)	113 (1000)	192 (1700)	508 (4500)
		2,3,9,15,21,30	34 (300)	90 (800)	136 (1200)	260 (2300)	565 (5000)
Max. Acceleration Output Torque $T_{acc r}$	Nm (in-lb)	1	28 (250)	56 (500)	141 (1250)	240 (2125)	636 (5625)
		2,3,9,15,21,30	42 (375)	113 (1000)	169 (1500)	324 (2875)	636 (5625)
Emergency ⁽¹⁾ Stop Output Torque $T_{em r}$	Nm (in-lb)	1	45 (400)	90 (800)	226 (2000)	384 (3400)	1017 (9000)
		2,3,9,15,21,30	68 (600)	181 (1600)	271 (2400)	520 (4600)	1130 (10,000)
Nominal Input Speed, $N_{nom r}$	RPM	1,2,3	3000	2600	2200	1800	1400
		9,15,21,30	3800	3400	3000	2400	1800
Max. Input Speed, $N_{max r}$	RPM	1,2,3	4000	3500	2900	2500	1600
		9,15,21,30	5300	4500	3800	3000	2300
Standard Backlash	arc-min	1,2,3	10	9	9	8	8
		9,15,21,30	12	11	11	10	10
Low Backlash	arc-min	1,2,3	6	5	5	4	4
		9,15,21,30	8	7	7	6	6
Efficiency at Nominal Torque	%	1,2,3	95	95	95	95	95
		9,15,21,30	92	92	92	92	92
Noise Level ⁽²⁾ at: 2,500 RPM 1,500 RPM	dB	All	70	70	70	—	—
			—	—	—	72	72
Torsional Stiffness	Nm/arc-min (in-lb/arc-min)	All	3 (28)	6 (56)	16 (140)	43 (380)	90 (800)
Maximum Weight	kg (lb)	All	7 (16)	13 (28)	25 (56)	54 (120)	114 (250)
Maximum Allowable Case Temperature	°C	All					100

(1) Maximum of 1,000 stops

(2) Measured at 1 meter

Stealth® MultiDrive Gearheads

MultiDrive RT/RD/RB Output Shaft Load Rating

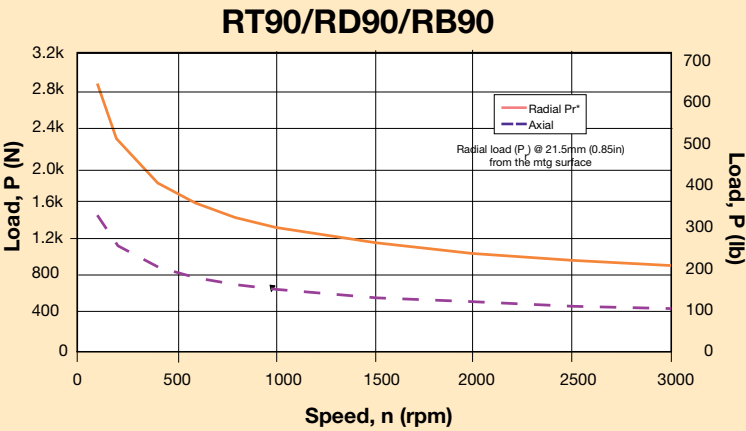

Formulas to calculate radial load (Prx) at any distance "X" from the gearhead mounting surface:

$$Prx = Pr * 121 \text{ mm} / (100 \text{ mm} + X)$$

$$Prx = Pr * 4.76 \text{ in} / (3.94 \text{ in} + X)$$

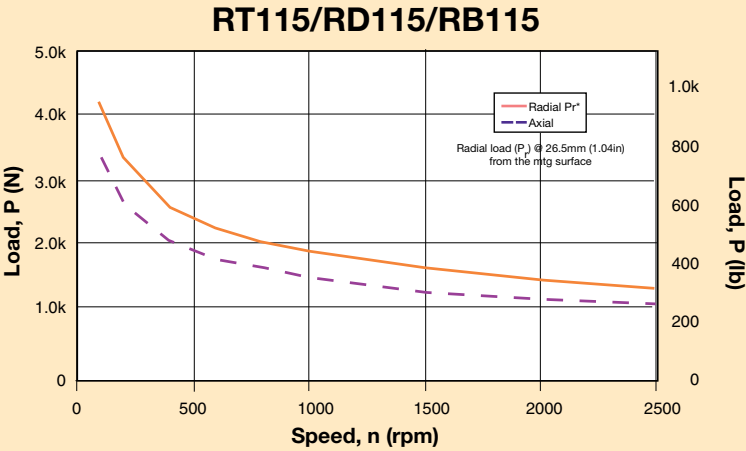

$$Prx = Pr * 151 \text{ mm} / (125 + X)$$

$$Prx = Pr * 5.94 \text{ in} / (4.92 \text{ in} + X)$$

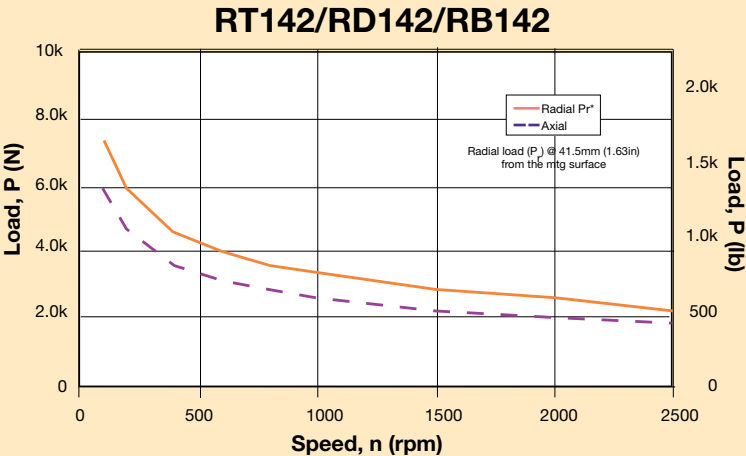

$$Prx = Pr * 201 \text{ mm} / (160 + X)$$

$$Prx = Pr * 7.91 \text{ in} / (6.30 \text{ in} + X)$$

MultiDrive RT/RD/RB Output Shaft Load Rating

RT180/RD180/RB180

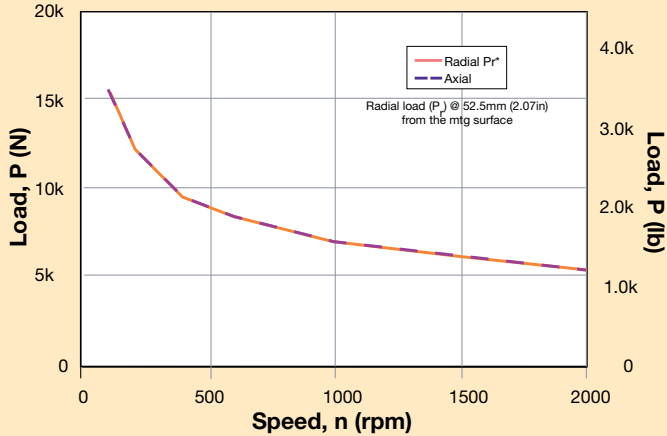

Formulas to calculate radial load (Prx) at any distance "X" from the gearhead mounting surface:

$$Prx = Pr * 260 \text{ mm} / (208 \text{ mm} + X)$$

$$Prx = Pr * 10.24 \text{ in} / (8.19 \text{ in} + X)$$

RT220/RD220/RB220

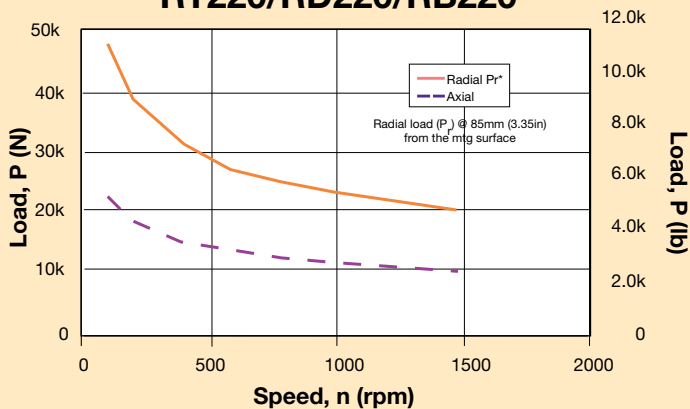

$$Prx = Pr * 352 \text{ mm} / (267 + X)$$

$$Prx = Pr * 13.86 \text{ in} / (10.5 \text{ in} + X)$$

Inertia

All moment of inertia values are as reflected at the input of the gearhead

		Frame Size (RT, RD, RB)				
Ratio	Units	R_90	R_115	R_142	R_180	R_220
1	gm-cm-sec ²	3.28	11.0	38.7	101	444
	oz-in-sec ²	0.046	0.153	0.538	1.41	6.17
2	gm-cm-sec ²	4.17	11.3	32.8	95.4	274
	oz-in-sec ²	0.058	0.157	0.455	1.32	3.81
3	gm-cm-sec ²	2.68	7.75	22.3	65.6	191
	oz-in-sec ²	0.037	0.108	0.311	0.911	2.65
9	gm-cm-sec ²	1.07	3.28	10.4	35.8	119
	oz-in-sec ²	0.015	0.046	0.145	0.497	1.66
15, 21, 30	gm-cm-sec ²	0.566	2.09	5.36	17.9	62.6
	oz-in-sec ²	0.008	0.029	0.075	0.248	0.869

Stealth® MultiDrive Gearheads

Dimensions – RT Hollow Shaft

Free 3D Solid Models and drawings available at parkermotion.com

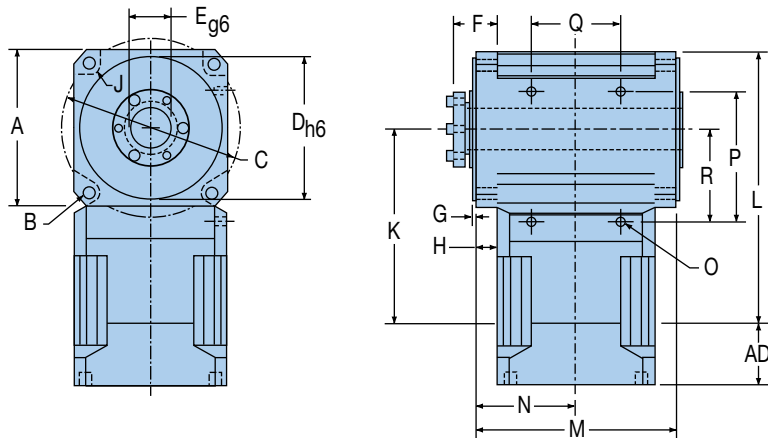

*AD=Adapter Length. Adapter will vary, depending on motor. (Visit our website or consult the factory for details.)

Frame Size	A		B		C		D		E		F		G		H	
	Square Flange		Bolt Hole		Bolt Circle		Pilot Diameter		- Bore Diameter *		Taper Bushing Extension		Pilot Thickness		Flange Thickness	
	mm	in	mm	in	mm	in	mm	in	mm	in	mm	in	mm	in	mm	in
RT90	90	3.543	6.5	0.256	100	3.937	80	3.150	22	0.866	26.5	1.043	3	0.118	12	0.472
RT115	115	4.528	8.5	0.335	130	5.118	110	4.331	30	1.181	31	1.220	3.5	0.138	14	0.551
RT142	142	5.591	11	0.433	165	6.496	130	5.118	38	1.496	43	1.693	3.5	0.138	20	0.787
RT180	182	7.165	13	0.512	215	8.465	160	6.299	48	1.890	54.2	2.134	10	0.394	25	0.984
RT220	220	8.661	17	0.669	250	9.843	180	7.087	60	2.362	74.1	2.917	15	0.591	35	1.378

Frame Size	J		K1		K2		L1		L2		M		N	
	Housing Recess		Distance to Output Centerline (For ratio = 3:1)		Distance to Output Centerline (For ratio > 3:1)		Housing Length (For ratio = 3:1)		Housing Length (For ratio > 3:1)		Housing Width		Distance to Input Centerline	
	mm	in	mm	in	mm	in	mm	in	mm	in	mm	in	mm	in
RT90	6.6	0.260	95	3.740	117	4.606	140	5.512	162	6.378	114	4.488	57	2.244
RT115	7.9	0.311	116	4.567	144.2	5.677	173.5	6.831	201.7	7.941	143	5.630	71.5	2.815
RT142	10.5	0.413	134	5.276	179	7.047	205	8.071	250	9.843	182	7.165	91	3.583
RT180	10	0.394	169	6.654	209.1	8.228	260	10.236	300.1	11.815	232	9.134	116	4.567
RT220	16	0.630	206	8.110	266	10.472	316	12.441	376	14.803	290	11.417	145	5.709

Both output flanges have identical dimensions.

*Maximum bushing bore diameter. Actual through bore of output shaft is larger. For additional bore diameter, contact Parker's Application Engineers for information.

Foot Mounting Holes Location

Frame Size	O	P		Q		R	
	Thread Size x Depth	mm	in	mm	in	mm	in
RT90	M4x6	80	3.150	60	2.362	60	2.362
RT115	M6x9	100	3.937	70	2.756	75	2.953
RT142	M8x12	120	4.724	80	3.150	85	3.346
RT180	M10x15	160	6.299	100	3.937	110	4.331
RT220	M12x20	195	7.677	130	5.118	136	5.354

Dimensions – RD Dual Shaft

Free 3D Solid Models and drawings available at parkermotion.com

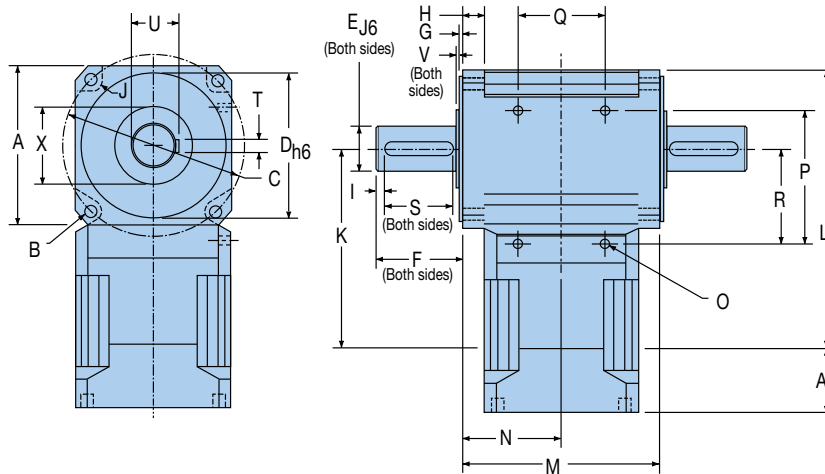

*AD=Adapter Length.
Adapter will vary,
depending on motor.
(Visit our website or consult
the factory for details.)

Frame Size	A		B		C		D		E		F		G		H		I		J	
	mm	in	mm	in	mm	in	mm	in	mm	in	mm	in	mm	in	mm	in	mm	in	mm	in
RT90	90	3.543	6.5	0.256	100	3.937	80	3.150	20	0.787	40	1.575	3	0.118	12	0.472	5	0.197	6.6	0.260
RT115	115	4.528	8.5	0.335	130	5.118	110	4.331	24	0.945	50	1.969	3.5	0.138	14	0.551	7	0.276	7.9	0.311
RT142	142	5.591	11	0.433	165	6.496	130	5.118	40	1.575	80	3.150	3.5	0.138	20	0.787	8	0.315	10.50	0.413
RT180	182	7.165	13	0.512	215	8.465	160	6.299	50	1.969	95	3.740	10	0.394	25	0.984	6	0.236	10	0.394
RT220	220	8.661	17	0.669	250	9.843	180	7.087	75	2.953	155	6.102	15	0.591	35	1.378	8	0.315	16	0.630

Frame Size	K1		K2		L1		L2		M		N		S		T		U		V		X	
	mm	in	mm	in	mm	in	mm	in	mm	in	mm	in	mm	in	mm	in	mm	in	mm	in	mm	in
RT90	95	3.740	117	4.606	140	5.512	162	6.378	114	4.488	57	2.244	28	1.102	6	0.236	22.5	0.886	2.5	0.098	45	1.575
RT115	116	4.567	144.2	5.677	173.5	6.831	201.7	7.941	143	5.630	71.52	2.815	32	1.260	8	0.315	27	1.063	2.5	0.098	50	1.969
RT142	134	5.276	179	7.047	205	8.071	250	9.843	182	7.165	91	3.583	63	2.480	12	0.472	43	1.693	2.5	0.098	50	1.969
RT180	169	6.654	209.1	8.228	260	10.236	300.111	11.815	232	9.134	116	4.567	70	2.756	14	0.551	53.52	2.106	2.5	0.098	55	2.165
RT220	206	8.110	266	10.472	316	12.441	376	14.803	290	11.417	145	5.709	100	3.937	20	0.787	79.5	3.130	2.5	0.098	100	3.937

Both output flanges have identical dimensions.

Foot Mounting Holes Location

Frame Size	Thread Size x Depth	O		P		Q		R	
		mm	in	mm	in	mm	in	mm	in
RT90	M4x6	80	3.150	60	2.362	60	2.362		
RT115	M6x9	100	3.937	70	2.756	75	2.953		
RT142	M8x12	120	4.724	80	3.150	85	3.346		
RT180	M10x15	160	6.299	100	3.937	110	4.331		
RT220	M12x20	195	7.677	130	5.118	136	5.354		

Encoder Mounting Option

	Dimensions For All Frame Sizes – mm (in)
Shaft Diameter	9.525 (0.375)
Shaft Length	19.050 (0.750)
Bolt Circle	74.981 (2.952)
Tapped Holes	M4x6 (Min. Depth)
Encoder (Not Supplied)	DRC C25, BEI E25, RENCO C2520

An additional flange is required on the gearhead for encoder mounting. it will increase the thickness of one output flange by 10mm.

Stealth® MultiDrive Gearheads

Dimensions – RB Low Ratio

Free 3D Solid Models and drawings available at parkermotion.com

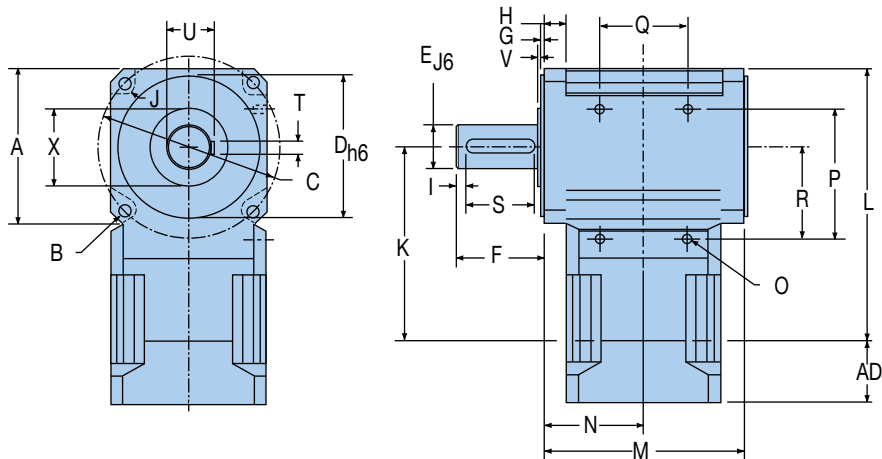

*AD=Adapter Length.
Adapter will vary,
depending on motor.
(Visit our website or consult
the factory for details.)

Frame Size	A		C		E		F		G		H		I		J	
	Square Flange		Bolt Circle		Output Shaft Diameter		Output Shaft Length		Pilot Thickness		Flange Thickness		Distance from Shaft End		Housing Recess	
	mm	in	mm	in	mm	in	mm	in	mm	in	mm	in	mm	in	mm	in
RT90	90	3.543	100	3.937	20	0.787	40	1.575	3	0.118	12	0.472	5	0.197	6.6	0.260
RT115	115	4.528	130	5.118	24	0.945	50	1.969	3.5	0.138	14	0.551	7	0.276	7.9	0.311
RT142	142	5.591	165	6.496	40	1.575	80	3.150	3.5	0.138	20	0.787	8	0.315	10.5	0.413
RT180	182	7.165	215	8.465	50	1.969	95	3.740	10	0.394	25	0.984	6	0.236	10	0.394
RT220	220	8.661	250	9.843	75	2.953	155	6.102	15	0.591	35	1.378	8	0.315	16	0.630

Frame Size	K		L		M		N		S		T		U		V		X	
	Distance to Output Centerline		Housing Length		Housing Width		Distance to Input Centerline		Keyway Length		Keyway Thickness		Keyway Height		Shoulder Height		Shoulder Diameter	
	mm	in	mm	in	mm	in	mm	in	mm	in	mm	in	mm	in	mm	in	mm	in
RT90	95	3.740	140	5.512	114	4.488	57	2.244	28	1.102	6	0.236	22.5	0.886	2.5	0.098	45	1.575
RT115	116	4.567	173.5	6.831	143	5.630	71.5	2.815	32	1.260	8	0.315	27	1.063	2.5	0.098	50	1.969
RT142	134	5.276	205	8.071	182	7.165	91	3.583	63	2.480	12	0.472	43	1.693	2.5	0.098	50	1.969
RT180	169	6.654	260	10.236	232	9.134	116	4.567	70	2.756	14	0.551	53.5	2.106	2.5	0.098	55	2.165
RT220	206	8.110	316	12.441	290	11.417	145	5.709	100	3.937	20	0.787	79.5	3.130	2.5	0.098	100	3.937

Both output flanges have identical dimensions.

Foot Mounting Holes Location

Frame Size	O	P		Q		R	
	Thread Size x Depth	mm	in	mm	in	mm	in
RT90	M4x6	80	3.150	60	2.362	60	2.362
RT115	M6x9	100	3.937	70	2.756	75	2.953
RT142	M8x12	120	4.724	80	3.150	85	3.346
RT180	M10x15	160	6.299	100	3.937	110	4.331
RT220	M12x20	195	7.677	130	5.118	136	5.354

Stealth® MultiDrive How to Order

Choose gearhead series, frame size, ratio, backlash and orientation from the chart below.

Gearhead Ordering Information

Order Example:		①	②	③	④	⑤	⑥
		RD	142	E	003	-	XXX LB
Series	Frame Size (mm)	Encoder	Ratio	Special	Backlash		
RB Low Ratio	090	—	001, 002, 003			Blank = Standard LB = Low	
	115						
	142						
	180						
	220						
RD Dual Shaft	090	E	001, 002, 003, 009, 015, 021, 030	Factory Assigned (Only if needed)		Blank = Standard LB = Low	
	115						
	142						
	180						
	220						
RT Hollow Shaft	090	—	003, 009, 015, 021, 030			Blank = Standard LB = Low	
	115						
	142						
	180						
	220						

Mounting Kit Ordering Information

For 1:1, 2:1 and 3:1 ratios, mounting kit is: MD (frame size)-ratio-xxx. For example MD90-001
 For 9:1 or higher, , mounting kit is: MT (frame size)-ratio-xxx. For example MD90-021

Parker MotionSizer sizing software available for free download at: www.parkermotion.com

Recommended Parker Motor and Mounting Kit

Frame Size	Ratio	Recommended Servo Motor			Recommended Stepper Motor		
		Motor	Mounting Kit	AD Dimension	Motor	Mounting Kit	AD Dimension
90	1:1, 2:1, 3:1	BE34 MPP092	MD90-209 MD90-016	24.5 mm	LV34 HV34	MD90-209	24.5 mm
	9:1 or Higher	BE34 MPP092	MT90-005 MT90-051	35.3 mm 44 mm	LV34 HV34	MT90-005	35.3 mm
115	1:1, 2:1, 3:1	MPP092 MPP115	MD115-017 MD115-010	26.5 mm 34.4-mm			
	9:1 or Higher	MPP092 MPP115	MT115-045 MT115-010	43.2 mm 51 mm			
142	1:1, 2:1, 3:1	MPP115 MPP142	MD142-010 MD142-013	40.8 mm 36 mm			
	9:1 or Higher	MPP115 MPP142	MT142-010 MT142-146	58 mm 75 mm			
180	1:1, 2:1, 3:1	MPP142 MPP190	MD180-123 MD180-125	36.4 mm 48 mm			
	9:1 or Higher	MPP142 MPP190	MT180-131 MT180-096	67.5 mm 109 mm			
220	1:1, 2:1, 3:1	MPP190 MPP220	MD220- MD-220	Consult Factory			
	9:1 or Higher	MPP190 MPP220	MT220-021 MT220-022	104 mm 138 mm			

Sizing/Selection Design Assistance

To properly size and select a gearhead for a specific application requires consideration of several interrelated parameters including: speed, continuous torque, repetitive peak torque or acceleration torque, emergency stop torque, duty cycle, ambient temperature and radial and axial shaft load.

The 9 step procedure on pages 72-73 provides a straightforward method of selecting the correct gearhead for your application.

NEMA Spur Gearheads

NE Series NEMA Spur Gearheads

Parker's NEMA gearheads feature a high-efficiency spur-gear design, in a light, compact package. Designed to mount directly to the face of NEMA face stepper and servo motors, NEMA gearheads are ideal for applications requiring low weight and low starting torque.

- Ratios from 3:1 to 100:1
- Lightweight, aluminum housing and spur gearing
- Compact, short overall length and direct mounting to NEMA 23, 34 and 42 frame size motors
- Low friction, low running torque, ideal for stepper motors



Product Series	Gear Geometry	Configuration	Frame Size	Continuous Torque (Nm)	Ratios	Backlash arc-min	IP Rating
NE	Spur	In-Line	NEMA 23, 34, 42	50 – 350	3, 5, 8, 10, 15, 20, 30, 50, 100	10 – 30	IP54

Direct Mount to NEMA Frame Motors

Gearheads attach directly to motors with NEMA mounting dimensions (see tables on following pages.) Parker's clamp-on-pinion and mounting hardware are included with gearheads, so your motor can be up and running in a matter of minutes.

Adapter Mount to Non-NEMA Frame Motors

For motors with non-NEMA dimensions, Parker supplies a mounting kit including a clamp-on-pinion, adapter plate and all necessary hardware. When



ordering, simply provide the part number or outline drawing of your motor, and the gearhead will be shipped ready to mount.

Performance Specifications

		Frame Size			
	Units	Ratio	NE23	NE34	NE42
Nominal Output Torque $T_{nom r}$	Nm (in-lb)	3	2 (16)	7 (64)	14 (123)
		5	3 (27)	12 (107)	23 (205)
		8-10	5 (40)	16 (142)	28 (250)
		15	5 (46)	19 (170)	34 (300)
		20 – 100	6 (50)	20 (180)	40 (350)
Max. Acceleration Output Torque $T_{acc r}$	Nm (in-lb)	3	3 (24)	11 (95)	21 (185)
		5	5 (40)	18 (160)	35 (307)
		8 – 10	7 (60)	24 (210)	42 (375)
		15	8 (70)	29 (255)	51 (450)
		20 – 100	9 (75)	31 (270)	59 (525)
Nominal Input Speed $N_{nom r}$	RPM	All	4000	4000	4000
Max. Input Speed $N_{max r}$	RPM	All	5500	5000	4500
Standard Backlash ¹⁾	arc-min	3, 5, 8, 10	30	25	25
		15 – 100	20	20	20
Low Backlash ¹⁾	arc-min	3, 5, 8, 10	15	15	15
		15 – 100	10	10	10
Efficiency at Nominal Torque	%	All	98%	98%	98%
Moment of Inertia	gm-cm-sec ² (oz-in-sec ²)	All	0.0051 (0.00007)	0.0408 (0.0005)	0.306 (0.004)
Maximum Weight	kg (lb)	All	0.5 (1.0)	1.4 (3.0)	3.0 (6.0)
Radial Load ²⁾	N (lb)	All	90 (20)	350 (80)	890 (200)
Axial Load	N (lb)	All	45 (10)	135 (30)	265 (60)

1) Measured at 2% of rated torque

2) Radial loads are measured at 12.7mm (0.5in) from the gearhead mounting surface. These ratings are based on gearhead making more than one revolution on output shaft.

NEMA Spur Gearheads

Dimensions – NE NEMA Spur Gearhead

Free 3D Solid Models and drawings available at parkermotion.com

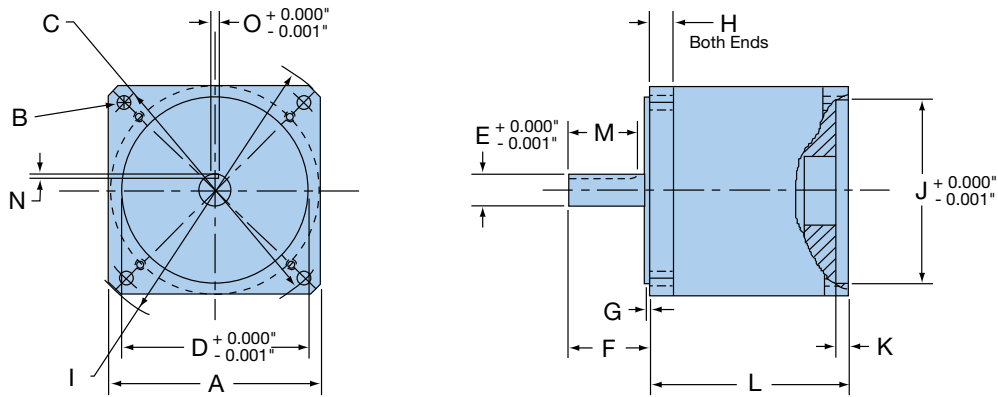

Frame Size	A		B		C		D		E		F		G		H	
	Square Flange		Bolt Hole		Bolt Circle		Pilot Diameter		Output Shaft Diameter		Output Shaft Length		Pilot Thickness		Flange Thickness	
	mm	in	mm	in	mm	in	mm	in	mm	in	mm	in	mm	in	mm	in
NE 23	58	2.27	5.0	0.195	66.7	2.625	38.1	1.500	9.5	0.375	25.4	1.00	1.6	0.062	5	0.19
NE 34	83	3.25	5.5	0.218	98.4	3.875	73.0	2.875	12.7	0.500	31.8	1.25	1.7	0.067	10	0.38
NE 42	107	4.20	7.1	0.281	125.7	4.950	55.5	2.187	15.9	0.625	38.1	1.50	2.4	0.093	13	0.50

Frame Size	I		J		K		L		M		N		O	
	Housing Diameter		Input Pilot Diameter		Input Pilot Depth		Housing Length		Keyway Length (Flat)		Keyway Depth (Flat)		Keyway Width	
	mm	in	mm	in	mm	in	mm	in	mm	in	mm	in	mm	in
NE 23	3.00	76	1.501	38.13	0.125	3.2	2.30	58	0.75	19	0.015	0.4	—	—
NE 34	4.38	111	2.876	73.05	0.200	5.1	3.00	76	1.06	27	0.072	1.8	0.124	3.15
NE 42	5.63	143	2.188	55.58	0.187	4.7	3.75	95	1.13	29	0.108	2.7	0.187	4.75

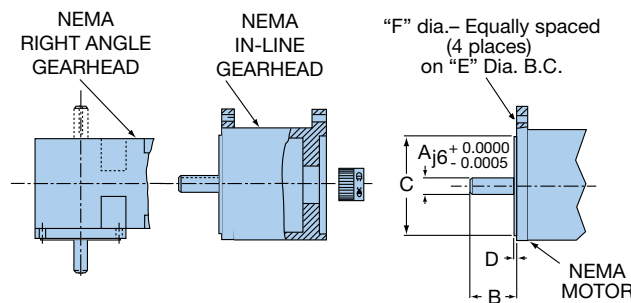

NEMA Motor Mounting Dimensions

Dimension	NE23		NE34		NE42		
	mm	in	mm	in	mm	in	
A	Motor Shaft Diameter	6.4	0.250	9.5/12.7	0.375/0.500	15.9	0.625
B	Motor Shaft Length	20.6	0.810	31.8	1.250	35.1	1.380
C	Pilot Diameter	38.1	1.500	73.0	2.875	55.5	2.186
D	Pilot Length	1.6	0.063	1.6	0.063	2.4	0.093
E	Mounting Bolt Circle	66.7	2.625	98.4	3.875	125.7	4.950
F	Bolt Hole Size	5.0	0.195	5.5	0.218	7.1	0.281

NE Series NEMA Gearheads How to Order

Choose gearhead series, frame size, ratio, backlash and orientation from the chart below.

Gearhead Ordering Information

Order Example:	①	②	③	④
	NE	34	- 010	- XXX - LB

①	②	③	④
Series	Frame Size	Ratio	Backlash
NE	23 34 42	003, 005, 008, 015, 020, 030, 050, 100	Blank = Standard LB = Low

Recommended Parker Motor and Mounting Kit

Frame Size	Recommended Servo Motor			Recommended Stepper Motor		
	Motor	Mounting Kit	AD Dimension	Motor	Mounting Kit	AD Dimension
23	BE23	MM23-136	0.78 in	LV23 HV23	MM23-000	No adapter (pinion gear only)
34	BE34	MM34-016	No adapter (pinion gear only)	LV34 HV34	MM34-171	0.65 in

Parker MotionSizer sizing software available for free download at: www.parkermotion.com

Sizing/Selection Design Assistance

To properly size and select a gearhead for a specific application requires consideration of several interrelated parameters including: speed, continuous torque, repetitive peak torque or acceleration torque, emergency stop torque, duty cycle, ambient temperature and radial and axial shaft load.

The 9 step procedure on pages 72-73 provides a straightforward method of selecting the correct gearhead for your application.

Servo Wheel™ Integral Gearmotors

Compact Wheel Drives for Electric Vehicles

Combining servo motor, gearing and wheel design makes system integration easy

The Servo Wheel™ combines a brushless DC motor with planetary gears in a lightweight, aluminum housing to provide a compact solution for vehicle control. The Power Wheel's unique design makes system integration easy. You no longer have to purchase the motor, gearhead, wheel, electronics and bracket from different sources. Parker does all of the work for you. From component sourcing to actual assembly, Parker engineers designed the Power Wheel with your application in mind. All you have to do is bolt it up and go!



Single-Piece Construction Motor Shaft

The first stage's planetary section sun gear is integrated into the single-piece construction motor shaft, to provide higher reliability in a compact package.



Planetary Gears

The planetary input stage provides a first pass reduction that is capable of carrying high torques with high input speeds in a small package.



Integrated Output Stage

The second stage planetary's unique design uses two planets for higher efficiency. Built entirely into the wheel, it utilizes an otherwise wasted area to provide a compact, space-saving package. Two large diameter bearings support the weight, protecting the gears from shock loading and dramatically increasing the radial load carrying capacity of the wheels.

Features:

Brushless DC motor amplifiers designed for common motion profiles in battery powered vehicles

- 12, 24, 36 and 48 volt operation
- Current and temperature feedback control for safe, reliable operation
- Multiple input architectures for easy communication with higher-level controllers and navigation systems

Permanent magnet brushless motors

- High efficiency for longer run times between battery charges
- Greater power to size ratio for a compact package
- Integral hall sensors for motor TRAP commutation
- Long life and maintenance free-operation
- High input speeds in excess of 10,000 RPM
- No internal sparking – safe in explosive environments
- Low EMI, eliminating the need for heavy shielding

Planetary gears provide high torque-carrying capability in a small package

The gears are built into the hub of the wheel, making the package compact and lightweight. This design also increases the radial load-carrying and shock loading capacity of the entire system.

Polyurethane tires are ideal for applications in hospitals, schools, and airports – any place requiring non-marking materials. This material is also ideal for high load carrying applications like material handling.

Design Features

- ① Polyurethane antistatic tires
- ② High load capacity ball bearings to accommodate heavy vehicle loads
- ③ Single piece stainless steel gears and shaft for high quality and reliability
- ④ Dual stage planetary gear design delivers high torque and high efficiency in a compact package
- ⑤ Brushless motor provides efficient, maintenance-free power
- ⑥ Encoder/brake extension for optional add-ons
- ⑦ Sealed unit for operation in hostile or wet environments
- ⑧ Aluminum alloy housing reduces weight and provides optimum heat dissipation

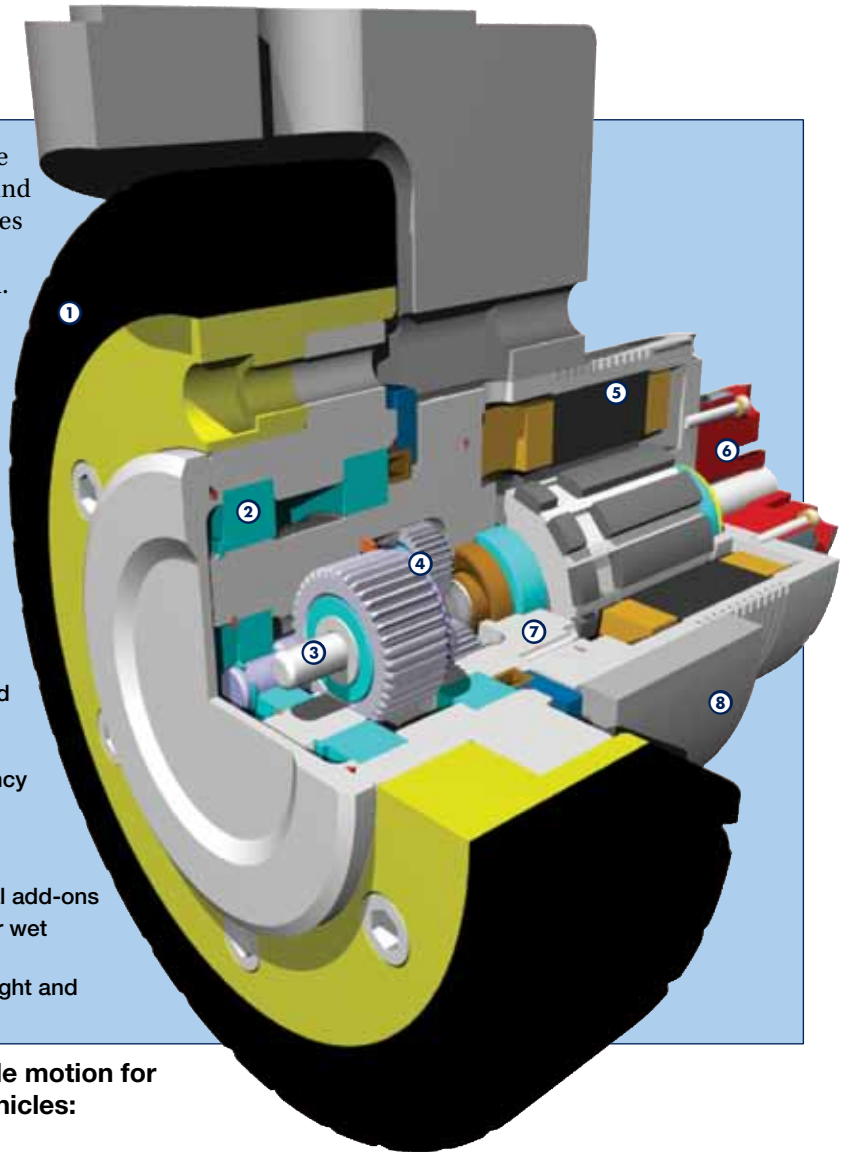

Servo Wheel™ Drive System provide motion for small, battery-powered, electric vehicles:

- Automated cleaning equipment
- Health care equipment
- Robotic & material handling equipment
- AGV's



Servo Wheel™ Integral Gearmotors

Performance Specifications*

		High Speed Motor Performance Models				High Torque Motor Performance Models			
Wheel Diameter (inches)	Ratio	Max Speed (mph)	Wheel RPM @ Max Speed	Continuous Torque (in -lb)	Peak Torque	Max Speed (mph)	Wheel RPM @ Max Speed	Continuous Torque (in -lb)	Peak Torque
		6	20:1	3.5	196	150	450	3.0	168
24:1	2.7		151	180	540	2.5	140	408	1224
30:1	2.3		128	225	675	2.0	112	510	1530
36:1	2.0		112	270	810	1.5	84	612	1836
8	20:1	4.5	189	150	450	3.8	159	340	1020
	24:1	3.6	151	180	540	3.0	126	408	1224
	30:1	3.0	126	225	675	2.5	105	510	1530
	36:1	2.5	105	270	810	2.0	84	612	1836

* All models have a maximum load capacity of 1000 lbs. Performance based on 24 volt operation. Other performance requirements may be met with a different power supply or choice of different motor winding. Please contact Parker Application Engineering to inquire about these options.

Motor Constants**

	Units	High Speed Motor Performance Models	High Torque Motor Performance Models
Stall Current Continuous	Arms	22.2	41.5
	Amps DC	27.1	50.8
Peak Current	Arms	70.0	131.1
	Amps DC	85.7	160.6
Voltage Constant	V/rad/s	0.0377	0.0515
	Vrms/krpm	2.79	3.81
Torque Constant	Nm/Arms	0.046	0.06
	oz-in/Amp DC	5.33	7.29
Resistance	ohm	0.070	0.033
Inductance	mH	0.1	0.1
DC bus Voltage	VDC	24	24
Winding Thermal Resistance	°C/W	Ambient	1.68
		Case	0.56
Temperature	°C	Ambient	25
		Max Winding	155
Thermal Time Constant	minutes	Motor	22
		Winding	1.7
Rotor Shaft	Nm/krpm	Viscous Damping	0.0021
		Dynamic Friction	0.0060
Number of rotor magnet poles		8	12

** Motors used as standard are Parker K064100-3D motor for High Speed Models and K089100-1D winding for High Torque Models.

Dimensions

Free 3D Solid Models and drawings available at parkermotion.com

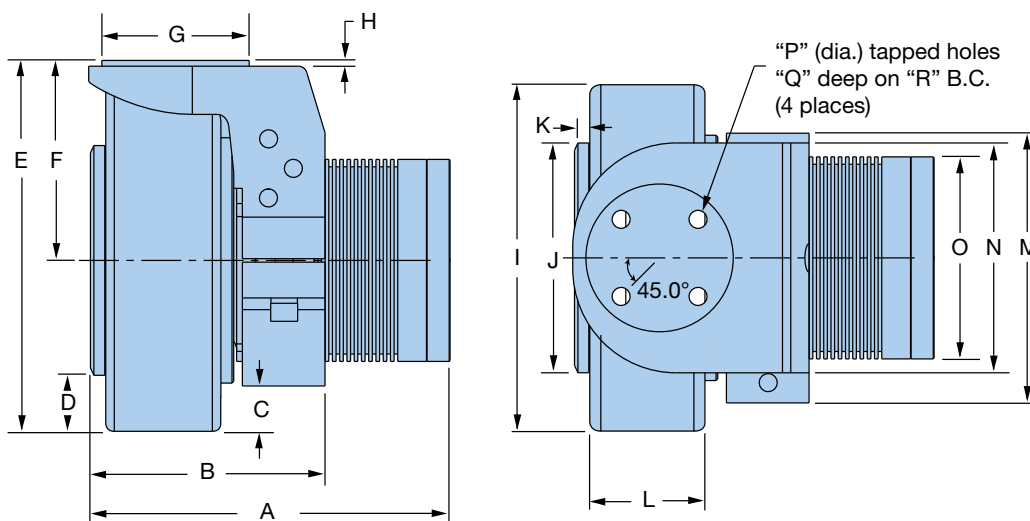

Wheel Diameter (in)	Motor Performance	A*		B		C		D		E		F	
		Without Brake											
		mm	in	mm	in	mm	in	mm	in	mm	in	mm	in
6	High Speed	158.75	6.25	104.1	4.1	20.3	0.8	25.4	1.0	165.1	6.5	87.9	3.46
	High Torque	175.26	6.90	104.1	4.1	20.3	0.8	25.4	1.0	165.1	6.5	87.9	3.46
8	High Speed	158.75	6.25	104.1	4.1	45.7	1.8	50.8	2.0	218.4	8.6	116.8	4.60
	High Torque	175.26	6.90	104.1	4.1	45.7	1.8	50.8	2.0	218.4	8.6	116.8	4.60

Wheel Diameter (in)	Motor Performance	G		H		I		J		K		L	
		mm	in	mm	in	mm	in	mm	in	mm	in	mm	in
6	High Speed	65.0	2.559	2.54	0.1	152.4	6.0	101.1	3.98	6.86	0.27	50.8	2.0
	High Torque	65.0	2.559	2.54	0.1	152.4	6.0	101.1	3.98	6.86	0.27	50.8	2.0
8	High Speed	65.0	2.559	2.54	0.1	203.2	8.0	101.1	3.98	6.86	0.27	50.8	2.0
	High Torque	65.0	2.559	2.54	0.1	203.2	8.0	101.1	3.98	6.86	0.27	50.8	2.0

Wheel Diameter (in)	Motor Performance	M		N		O		P		Q		R	
		mm	in	mm	in	mm	in	mm	in	mm	in	mm	in
6	High Speed	118.6	4.67	101.1	3.98	88.9	3.5	7.94	5.16	25.4	1.0	47.98	1.889
	High Torque	118.6	4.67	101.1	3.98	88.9	3.5	7.94	5.16	25.4	1.0	47.98	1.889
8	High Speed	118.6	4.67	101.1	3.98	88.9	3.5	7.94	5.16	25.4	1.0	47.98	1.889
	High Torque	118.6	4.67	101.1	3.98	88.9	3.5	7.94	5.16	25.4	1.0	47.98	1.889

* Consult factory for increased length with encoder and on brake option.

Servo Wheel™ Integral Gearmotors

Digital Servo Amplifier Accessory

Provides High Current Control for Servo Wheel™ Drives

This digital servo amplifier provides DSP-based digital closed-loop, four-quadrant PWM control of force or torque of permanent magnet, linear or rotary, brush or brushless DC motors. Our PWM current control algorithm, current sensing method, and advanced switching scheme yields performance comparable to a linear servo amplifier.

This digital drive will reduce expensive motor drive stocking requirements because it will control brush-type, brushless-trapezoidal and brushless-sinusoidal motors.

Setup is easy. The operating configuration – motor type, motor parameters, operating voltage, peak and continuous current limits and system parameters for velocity or position control are all input by the user to a PC-based setup program that automatically downloads the information, with the computed algorithm, into the flash memory of the drive via an RS-232 port. The drive can be reconfigured at any time by running the setup-program.

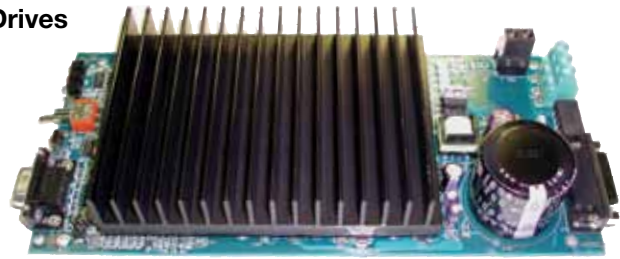

Features

- **High-performance DSP-based servo controls motor force or torque. Control of velocity or position using the motor's Hall of encoder signals is an option**
- **Controls brush-type, brushless-trapezoidal and brushless-sinusoidal motors**
- **User inputs motor parameters, voltage, peak and continuous current limit into Windows-based setup software. Setup software automatically downloads the algorithm for a 2kHz current loop bandwidth via RS-232 communications**
- **Proprietary PWM software controlled switching scheme yields ultra-low ripple at low current levels, zero crossover distortion, and minimizes EMI in noise sensitive applications**
- **Differential amplifiers accept a single $\pm 10V$ analog current command for trapezoidal brushless and brush type motors**
- **Optional inputs allow digital commands through the RS-232 or serial peripheral interface**
- **3 output current ranges and scale factors available**
- **Optically isolated digital inputs for Enable/Reset, Brake, and \pm Travel Limits**
- **Motor current monitor output, and optically isolated digital outputs provide controller fault indication**
- **Configurator program provides drive status and fault history via RS-232 link**
- **Fault protection makes this drive virtually indestructible**
- **Operates from one low-cost 24 – 48 VDC unregulated power supply or battery**

Specifications

Part Number	11564041	11564045
Input Power Bus	24 to 48 VDC	24 to 48 VDC
Continuous Output Power (Max.)	450 watts ¹	1350 watts ¹
Continuous Output Current	10 amps ¹	15 amps ¹
Peak Output Current	20 amps ¹ (1 sec typ.)	40 amps ¹
Scale Factor (A / V)	2	6
Voltage @ Continuous Output Current	Input Bus Voltage – 3 Volts Typ.	Input Bus Voltage – 3 Volts Typ.
Max Heat Sink Temperature	Disables if >70°C	Disables if >70°C
Current Loop Bandwidth	2 kHz Typ.	2 kHz Typ.
Switching Frequency	40 kHz	40 kHz
Minimum Maintenance	100 UH	100 UH
Weight	25 oz	25 oz

¹ Depends on ambient operating temperature and heat sink. For the >10 amperes continuous output, we recommend forced convection cooling with a minimum airflow of 100 CFM. Consult factory for assistance.

Operating Control Signals and Indicators

Input Analog Control Signal	±10 Volts
Digital Input Commands	Rs-232, SPI
Peak Current limit	Software adjustable
Continuous Current Limit	Software adjustable
Drive Enable/Reset	5V logic, optically isolated
(+) Travel Limit	5V logic, optically isolated
(-) Travel Limit	5V logic, optically isolated
Brake	5V logic, optically isolated
Fault and/or Brake Status	5V logic, optically isolated
Drive Enabled indicator	Green LED
Brake Indicator	Red LED
Fault Indicator	Red LED
Digital Hall Effect Sensors	3 channels,+5 Volts,Gnd

Mounting Dimensions

(inches)

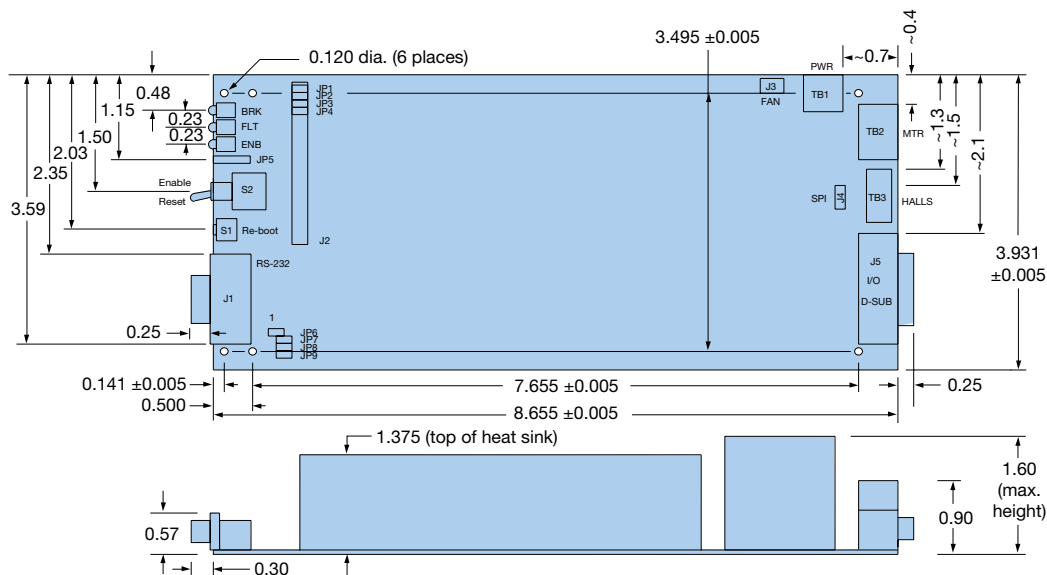

Servo Wheel™ Integral Gearmotors

DX Series Servo Wheel How to Order

Choose wheel size, ratio, motor performance, supply voltage, tire material, and brake option from the chart below.

Servo Wheel Ordering Information

① ② ③ ④ ⑤ ⑥ ⑦

Order Example: DX A 1 1 K S 3

①	②	③	④	⑤	⑥	⑦
Series	Wheel Size (Diameter)	Ratio	Motor Performance	Supply Voltage	Tire Material	Brake/Encoder
DX	A = 6" B = 8"	1 = 20:1 2 = 24:1 3 = 30:1 4 = 36:1	1 = High speed 2 = High torque	K = 24 VDC X = Other	S = Polyurethane black x tread R = Polyurethane black (Other tire compositions available upon request)	0 = None 1 = Encoder 2 = Brake 3 = Encoder & Brake (50 in-lb)

Related Products from Parker

K Series Frameless Kit Motors



Frameless kit motors are the ideal solution for machine designs that require high performance in small spaces. Kit motors are directly integrated with the drive train, resulting in a smaller, more reliable motor package.

Direct drive motion construction also gives equipment designers the advantages of lower costs, increased reliability and improved performance.

When to Use

- **A significant cost savings**
- **Reduced mechanical complexity**
- **Greater design flexibility**
- **High performance in a compact package**
- **Improved dynamic response and settling**
- **Minimum motor size per application space**
- **Low cogging for smooth operation**
- **Low inertia for high acceleration**

Features

- **High peak torque up to 93.37 Nm (826.4 in-lb)**
- **High speeds up to 50,000 RPM**
- **Superior performance – high stiffness and better response**
- **High reliability – no mechanical couplings**
- **Compact design – minimizes product size**
- **Low cogging - special orientation of the laminations and odd slot count**
- **Very low torque ripple at low speeds for smooth and precise rotary motion**

MPP/MPJ Series Rotary Servo Motors



The MaxPlusPlus (MPP) family of brushless servo motors is redefining performance, flexibility, and reliability. The industry's highest-performing servo motor uses eight-pole segmented lamination technology, which produces more torque in a shorter package. Use MaxPlusPlus motors for higher torque applications, customization options, or when high performance is required.

When higher inertia is desired to improve system performance, the MPJ is the perfect choice. It includes all the same features and benefits of the MPP, but increases the rotor inertia by 3 to 8 times over the standard MPP.

- **MPP – 92 to 270 mm frame sizes**
MPJ – 92 to 142 mm frame sizes
- **1.5 to 158 Nm (13 to 1398 in-lb) continuous stall torque**
- **4.3 to 402 Nm (38.1 to 3558 in-lb) peak torque**
- **Very high torque-to-inertia ratio**
- **Right-angle rotatable connectors**
- **Seven different feedback devices including encoder, serial encoder, resolver, Heidenhain and Stegmann single and multi-turn absolute encoders**
- **IP64 standard, IP65 optional**
- **Special shaft, front flange, and feedback devices available**
- **CE and UL**

Related Products from Parker

RD Series Direct Drive Servo Rotary Positioners



Parker direct drive rotary stages feature a robust construction and high performance in a compact package, providing smooth, near frictionless motion with zero backlash.

Featuring an integral brushless DC servo motor, these rotary stages offer several distinct advantages over traditional worm gear-driven stages. The elimination of the worm gearing offers the ability to reduce wear with zero backlash while exhibiting near frictionless motion.

The RD's high positioning accuracy, solely based on the stage's encoder, provides repeatability within 2 encoder counts, with resolutions down to 1.4 arc-seconds. The RD Direct Drive features speeds up to 700 RPM with significant torque capability.

- **Robust bearing design for high load capacity**
- **Integrated brushless motor features high copper slot fill and rare earth magnets for maximum torque efficiency**
- **In-line rotary encoder for direct position feedback. Also includes once per rev index mark**
- **Aluminum or stainless steel precision ground top plate for accurate mounting**
- **Motor rotor and top plate shaft as one-piece construction for high stiffness**
- **Sub "D" connectors for "plug & play" operation and simple connectivity**

Compax3 Servo Drives & Drive/Controllers



With its high performance and modular design, the Compax3 family of industrial servo drives and drive/controllers offers a new level of servo performance and flexibility.

Enhanced by the IEC 61131-3 programming environment, the modular structure of the Compax3

family allows options such as intelligent motion controllers, fieldbus interfaces and industry standard motor feedback.

Available in single- or multi-axis configurations, with numerous expansion options, all models are rated for 120 - 480 VAC input, continuous current output from 2.5 A (rms) to 155 A (rms), and are CE (EMC & LVD) and UL compliant.

Compax3 Drive

- **5V/24V step/direction and $\pm 10V$ analog command**
- **Resolver, encoder or high-resolution SinCos[®] Hiperface[™] and Endat 2.1**
- **Torque, velocity or position control modes**
- **Encoder tracking capability**

Compax3 Drive/Controller

- **Available as:**
 - servo positioning
 - programmable positioning with function modules according to PLCopen
 - advanced programmable positioning with electronic camming, gearing, etc.
- **Certified safety technology integrated into drive (EN954-1 Category 3)**
- **Fieldbus options: DeviceNet, Profibus, CANopen, ETHERNET Powerlink and RS232**
- **Supports all five IEC 61131-3 programming languages and continuous flow chart**
- **Resolver, encoder or high-resolution Sin/Cos[®], Hiperface[™], Endat 2.1 and SSI feedback devices**

Aries Servo Drives & Drive/Controllers



The Aries Series are compact, easy-to-use servo motor drives and drive/controllers. Aries is a cost-effective and flexible digital servo solution where users are required to pay for only the performance they need. All models are CE (EMC & LVD), UL compliant.

Aries Drive

The Aries Drive is standard as a torque-only amplifier, but is software selectable to run in velocity mode. An optional step-and-direction version is also available.

- **120/240 VAC input**
- **100 to 3000 W power levels**
- **Plug in and spin – no set up required; auto-configures when used with Parker’s “smart encoder” motor**
- **Drive Talk – ACR9000 controller can access all drive parameters**
- **Supported feedback devices include Smart encoder, quadrature encoder, Heidenhain EnDat absolute encoder and resolver**

Aries Drive/Controller

The Aries Controller combines the versatile and cost-effective Aries digital servo drive platform with the advanced control capabilities of the ACR servo controller into a single-axis drive/controller.

- **Ethernet TCP/IP communications**
- **400 to 1300 W power levels**
- **1 1/2 axis encoder input for camming, following, and gearing**
- **Up to 16 multi-tasking programs**
- **Set-up and auto-tuning via ACR-View SDK**
- **Supports EtherNet/IP**

HPLA/HLE Series Industrial Belt-Driven Positioners



The HLE/HPLA linear modules are ideal as single-axis products or as components for high-speed multi-axis gantries. With thousands of units in operation worldwide, the HPLA/HLE Series are proven performers offering long life and with trouble-free operation.

With flexible design options for bearing selection, profile size, stroke length, and motor/gearbox combination, the HPLA/HLE design has your application covered.

- **Rugged construction for heavy duty applications**
- **Thrust force capacity to 5455 N**

- **Standard travel up to 9 meters**
- **Velocity up to 5 meters/sec.**
- **Positional repeatability of ± 0.2 mm**
- **Timing belt and pulley drive mechanism for fast, accurate positioning**
- **Increased system stiffness due to larger belt width**
- **Low-maintenance sealed bearings**
- **Hollow-shaft input option for higher axial forces**
- **Steel-wheel or square-rail designs for normal load capacities up to 15 kN**
- **Quiet operation**
- **Corrosion-resistant option for harsh environments**
- **IP30 seal design**

Gearhead Sizing/Selection

Stealth® Gearhead 9 Step Sizing/Selection Procedure

To properly select an appropriate gearhead for a specific application requires consideration of several interrelated parameters including:

- **Speed**
- **Continuous torque**
- **Repetitive peak torque or acceleration torque**
- **Emergency stop torque**
- **Duty cycle**
- **Ambient temperature**
- **Radial and axial shaft load**

The following 9 step procedure provides a quick, straightforward method for selecting a gearhead that will provide an L-10 life of 10,000 hours.

1) Load Parameters

Evaluate the following requirements of the load:

- Load inertia
- Acceleration time (t_{acc})
- Continuous run time (t_{cont})
- Deceleration time (t_{dec})
- Dwell time (t_{dwell})
- Maximum continuous speed (N_{cont})

From these, calculate:

- Acceleration torque (T_{acc})
- Continuous torque (T_{cont})
- Deceleration torque (T_{dec})
- Dwell torque (T_{dwell})*

*Although not used in the following torque calculations, torque requirements during dwell (zero speed) must be considered when selecting gearhead size.

2) Duty Cycle

Determine if the application duty cycle is **intermittent** or continuous by calculating the duty cycle as follows:

$$\text{Duty cycle} = (t_{acc} + t_{cont} + t_{dec} / t_{total}) \times 100\%$$

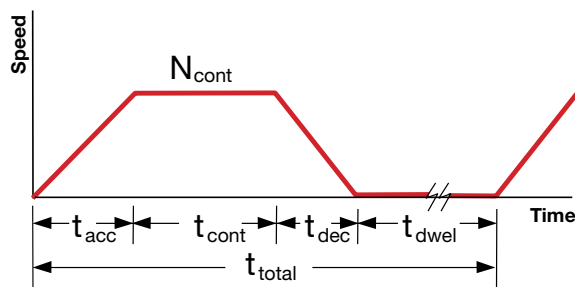

If the duty cycle is <60% and ($t_{acc} + t_{cont} + t_{dec}$) is less than 20 minutes, the motion is considered **intermittent**.

If the duty cycle is $\geq 60\%$ and ($t_{acc} + t_{cont} + t_{dec}$) is greater than 20 minutes, the motion is considered **continuous**.

3) Calculate the Root Mean Cube Output Torque

$$T_{mean} = \sqrt[3]{\frac{\left[\frac{(T_{acc})^3(N_{cont})(t_{acc}) + (T_{cont})^3(N_{cont})(t_{cont}) + (T_{dec})^3(t_{dec}) \right]}{2}}{\left[\frac{(N_{cont})(t_{acc}) + (N_{cont})(t_{cont}) + (N_{cont})(t_{dec}) \right]}}$$

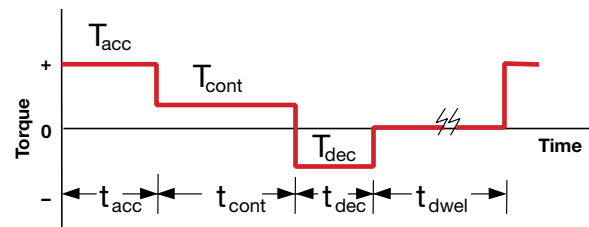

4) Select Gearhead Type and Size

Choose the gearhead type (PS, PX, etc) and frame size to match the motor frame size.

5) Check Selected Gearhead Size Ratings

Check the specifications of the gearhead selected and confirm that it meets the following criteria:

$$\text{Rated nominal torque } (T_{nom}) \geq T_{mean}$$

$$\text{Rated accel torque } (T_{acc r}) \geq T_{acc} \text{ or } T_{dec}$$

6) Determine Maximum Allowable Gearhead Ratio

Using the selected gearhead's listed specification for maximum rated speed (N_{maxr}), determine the maximum allowable ratio:

$$\text{Maximum ratio} = N_{maxr} / N_{cont}$$

7) Calculate the Mean and Maximum Input Speed

Choose a ratio for the selected gearhead (must be less than the maximum determined in Step 6). With this ratio, calculate the mean input speed ($N_{mean i}$) and the maximum input speed ($N_{max i}$):

$$N_{mean i} = \left(\frac{\left(\frac{(N_{cont})(t_{acc}) + (N_{cont})(t_{cont}) + (N_{cont})(t_{dec}) \right)}{2}}{t_{acc} + t_{cont} + t_{dec}} \right) (\text{ratio})$$

$$N_{max i} = (N_{cont}) (\text{ratio})$$

Note: Reflected inertia requirement may determine the actual ratio, as long as it does not exceed the maximum ratio value calculated in Step 6.

8) Determine Thermal (KT) and Shock (KS) Factor

Use the selected gearhead's specifications and the K Factor charts below to compensate for thermal and shock torque effects to comply with the following:

For continuous duty: $T_{nom r} > (T_{mean})(K_T)(K_S)$

For intermittent duty: $T_{nom r} > (T_{mean})(K_S)$

K_T Thermal Factor

This factor derates the transmitted torque to prevent case temperature from exceeding 100°C. The K_T values shown in the table below are for 25°C ambient temperature, medium-size indoor space, with the gearheads mounted to a metal base with a surface area more than 3 times larger than the gearhead surface area.

K_S Shock Factor

This factor is used to derate the transmitted torque when the application is not well defined, has random duty cycles or experiences varying peak torques subjecting the gear teeth to torques above the estimated torques. K_S factor values are shown below for three general application categories. K_S values are independent of gearhead size. If your application does not fit into one of these categories, contact Parker to discuss your requirements.

9) Confirm Selection

Using the selected gearhead's listed specifications and the calculations from the previous steps, check that the following criteria are met:

- T_{accr} must be greater than the larger of T_{acc} or T_{dec}
- Check the emergency stop torque rating
- N_{nomr} must be greater than $N_{mean i}$
- N_{maxr} must be greater than $N_{max i}$
- Verify radial and axial shaft load

If any of the above comparisons are not met, then:

- Choose a larger gearhead
- Reevaluate the ratio
- Reevaluate the torque
- Reevaluate the speed
- Reevaluate the duty cycle
- Reevaluate shaft load

K_S Shock Factor

Load Type	Application	K_S
Known Load Data	All Industries	1.00
Unknown Load Data – Light	Textiles, liquid mixers, can filling, food, conveyors, plastics, fans	1.25
Unknown Load Data – Moderate	Paper mills, rubber industry, sugar industry, metal mills, lumber, robotics	1.50

K_T Thermal Factor

Frame Size	Ratio	K_T Factor @ Designated Output Speed (RPM)									
		100	200	400	600	800	1000	1500	2000	2500	3000
PV40		1	1	1	1	1	1	—	—	—	—
PS, PX, PV, RS60		1	1	1	1	1	1	—	—	—	—
PS, PX, PV, RS90		1	1	1	1	1	1.2	—	—	—	—
PS, PX, RS115		1	1	1	1	1.2	1.5	—	—	—	—
PS, RS142		1	1	1	1.3	1.7	—	—	—	—	—
PS, RS180	1 stage ⁽¹⁾	1	1	1.5	2.3	—	—	—	—	—	—
	2 stage ⁽²⁾	1.1	1.5	—	—	—	—	—	—	—	—
PS, RS220	1 stage ⁽¹⁾	1	1.2	2.1	3.2	—	—	—	—	—	—
	2 stage ⁽²⁾	1.3	2.5	—	—	—	—	—	—	—	—
PS, RS300	1 stage ⁽¹⁾	1	1.5	3.1	—	—	—	—	—	—	—
	2 stage ⁽²⁾	1.9	—	—	—	—	—	—	—	—	—
RT, RD, RB90	1	1	1	1	1	1	1	1	1	1.25	1.5
	2-30	1	1	1	1	1	1	1.1	—	—	—
RT, RD, RB115	1	1	1	1	1	1	1	1	1.3	1.7	—
	2-30	1	1	1	1	1	1.3	2	—	—	—
RT, RD, RB142	1	1	1	1	1	1	1.3	2	2.7	3.4	—
	2-30	1	1	1	1	1.3	1.6	—	—	—	—
RT, RD, RB180	1	1	1	1	1	1.3	1.7	2.5	3.4	—	—
	2-30	1	1	1	1.4	1.8	2.3	—	—	—	—
RT, RD, RB220	1	1	1	1.2	1.8	2.4	3.0	4.5	—	—	—
	2-30	1	1	1.3	2.0	2.6	—	—	—	—	—

(1) Data given for PS 3:1 to 10:1 and all RS ratios

(2) Data given for PS ratios above 10:1

Offer of Sale

The items described in this document and other documents or descriptions provided by Parker, its subsidiaries and its authorized distributors are hereby offered for sale at prices to be established by Parker Hannifin Corporation, its subsidiaries and its authorized distributors. This offer and its acceptance by any customer ("Buyer") shall be governed by all of the following Terms and Conditions. Buyer's order for any such item, when communicated to Parker, its subsidiary or an authorized distributor ("Seller") verbally or in writing, shall constitute acceptance of this offer.

1. **Terms and Conditions of Sale:** All descriptions, quotations, proposals, offers acknowledgments, acceptances and sales of Seller's products are subject to and shall be governed exclusively by the terms and conditions stated herein. Buyer's acceptance of any offer to sell is limited to these terms and conditions. Any terms or conditions in addition to, or inconsistent with those stated herein, proposed by Buyer in any acceptance of an offer by Seller, are hereby objected to. No such additional, different or inconsistent terms and conditions shall become part of the contract between, Buyer and Seller unless expressly accepted in writing by Seller. Seller's acceptance of any offer to purchase by Buyer is expressly conditional upon Buyer's assent to all the terms and conditions stated herein, including any terms in addition to, or inconsistent with those contained in Buyer's offer. Acceptance of Seller's products shall in all events constitute such assent.

2. **Payment:** Payment shall be made by Buyer net 30 days from the date of delivery of the items purchased hereunder. Amounts not timely paid shall bear interest at the maximum rate permitted by law for each month or portion thereof that the Buyer is late in making payment. Any claims by Buyer for omissions or shortages in a shipment shall be waived unless Seller receives notice thereof within 30 days after Buyer's receipt of the shipment.

3. **Delivery:** Unless otherwise provided on the face hereof, delivery shall be made F.O.B. Seller's plant. Regardless of the method of delivery, however, risk of loss shall pass to Buyer upon Seller's delivery to a carrier. Any delivery dates shown are approximate only and Seller shall have no liability for any delays in delivery.

4. **Warranty:** Seller warrants that the items sold hereunder shall be free from defects in material or workmanship for a period of 12 months from date of shipment from Parker. THIS WARRANTY COMPRISES THE SOLE AND ENTIRE WARRANTY PERTAINING TO ITEMS PROVIDED HEREUNDER. SELLER MAKES NO OTHER WARRANTY, GUARANTEE, OR REPRESENTATION OF ANY KIND WHATSOEVER. ALL OTHER WARRANTIES, INCLUDING BUT NOT LIMITED TO, MERCHANTABILITY AND FITNESS FOR PURPOSE, WHETHER EXPRESS, IMPLIED, OR ARISING BY OPERATION OF LAW, TRADE USAGE, OR COURSE OF DEALING ARE HEREBY DISCLAIMED. NOTWITHSTANDING THE FOREGOING, THERE ARE NO WARRANTIES WHATSOEVER ON ITEMS BUILT OR ACQUIRED WHOLLY OR PARTIALLY, TO BUYER'S DESIGNS OR SPECIFICATIONS.

5. **Limitation of Remedy:** SELLER'S LIABILITY ARISING FROM OR IN ANY WAY CONNECTED WITH THE ITEMS SOLD OR THIS CONTRACT SHALL BE LIMITED EXCLUSIVELY TO REPAIR OR REPLACEMENT OF THE ITEMS SOLD OR REFUND OF THE PURCHASE PRICE PAID BY BUYER, AT SELLER'S SOLE OPTION. IN NO EVENT SHALL SELLER BE LIABLE FOR ANY INCIDENTAL, CONSEQUENTIAL OR SPECIAL DAMAGES OF ANY KIND OR NATURE WHATSOEVER, INCLUDING BUT NOT LIMITED TO LOST PROFITS ARISING FROM OR IN ANY WAY CONNECTED WITH THIS AGREEMENT OR ITEMS SOLD HEREUNDER, WHETHER ALLEGED TO ARISE FROM BREACH OF CONTRACT, EXPRESS OR IMPLIED WARRANTY, OR IN TORT, INCLUDING WITHOUT LIMITATION, NEGLIGENCE, FAILURE TO WARN OR STRICT LIABILITY.

6. **Changes, Reschedules and Cancellations:** Buyers may request to modify the designs or specifications for the items sold hereunder as well as the quantities and delivery dates thereof, or may request to cancel all or part of this order, however, no such requested modification or cancellation shall become part of the contract between Buyer and Seller unless accepted by Seller in a written amendment to this Agreement. Acceptance of any such requested modification of cancellation shall be at Seller's discretion, and shall be upon such terms and conditions as Seller may require.

7. **Special Tooling:** A tooling charge may be imposed for any special tooling, including without limitation, dies, fixtures, molds and patterns, acquired to manufacture items sold pursuant to this contract. Such special tooling shall be and remain Seller's property notwithstanding payment of any charges by Buyer. In no event will Buyer acquire any interest in apparatus belonging to Seller which is utilized in the manufacture of the items sold hereunder, even if such apparatus has been specially converted or adapted for such manufacture

and not withstanding any charges paid by Buyer. Unless otherwise agreed, Seller shall have the right to alter, discard or otherwise dispose of any special tooling or other property in its sole discretion at any time.

8. **Buyer's Property:** Any designs, tools, patterns, materials, drawings confidential information or equipment furnished by Buyer, or any other items which become Buyer's property, may be considered obsolete and may be destroyed by Seller after two (2) consecutive years have elapsed without Buyer placing an order for the items which are manufactured using such property. Seller shall not be responsible for any loss or damage to such property while it is in Seller's possession or control.

9. **Taxes:** Unless otherwise indicated on the face hereof, all prices and charges are exclusive of excise, sales, use, property, occupational or like taxes which may be imposed by any taxing authority upon the manufacture, sale or delivery of the items sold hereunder. If any such taxes must be paid by Seller or if Seller is liable for the collection of such tax, the amount thereof shall be in addition to the amounts for the items sold. Buyer agrees to pay all such taxes or to reimburse Seller therefore upon receipt of its invoice. If Buyer claims exemption from any sales, use or other tax imposed by any taxing authority, Buyer shall save Seller harmless from and against any such tax, together with any interest or penalties thereon which may be assessed if the items are held to be taxable.

10. **Indemnity For Infringement of Intellectual Property Rights:** Seller shall have no liability for infringement of any patents, trademarks, copyrights, trade dress, trade secrets or similar rights except as provided in this Part 10. Seller will defend and indemnify Buyer against allegations of infringement of U.S. patents, U.S. trademarks, copyrights, trade dress and trade secrets (hereinafter "Intellectual Property Rights"). Seller will defend at its expense and will pay the cost of any settlement or damages awarded in an action brought against Buyer based on an allegation that an item sold pursuant to this contract infringes the Intellectual Property Rights of a third party. Seller's obligation to defend and indemnify Buyer is contingent on Buyer notifying Seller within ten (10) days after Buyer becomes aware of such allegations of infringement, and Seller having sole control over the defense of any allegations or actions including all negotiations for settlement or compromise. If an item sold hereunder is subject to a claim that it infringes the Intellectual Property Rights of a third party, Seller may, at its sole expense and option, procure for Buyer the right to continue using said item, replace or modify said item so as to make it non infringing, or offer to accept return of said item and return the purchase price less a reasonable allowance for depreciation. Notwithstanding the foregoing, Seller shall have no liability for claims of infringement based on information provided by Buyer, or directed to items delivered hereunder for which the designs are specified in whole or part by Buyer, or infringements resulting from the modification, combination or use in a system of any item sold hereunder. The foregoing provisions of this Part 10 shall constitute Seller's sole and exclusive liability and Buyer's sole and exclusive remedy for infringement of Intellectual Property Right. If a claim is based on information provided by Buyer or if the design for an item delivered hereunder is specified in whole or in part by Buyer, Buyer shall defend and indemnify Seller for all costs, expenses or judgments resulting from any claim that such item infringes any patent, trademark, copyright, trade dress, trade secret or any similar right.

11. **Force Majeure:** Seller does not assume the risk of and shall not be liable for delay or failure to perform any of Seller's obligations by reason of circumstances beyond the reasonable control of Seller (hereinafter "Events of Force Majeure"). Events of Force Majeure shall include without limitation, accidents, acts of God, strikes or labor disputes, acts, laws, rules or regulations of any government or government agency, fires, floods, delays or failures in delivery of carriers or suppliers, shortages of materials and any other cause beyond Seller's control.

12. **Entire Agreement/Governing Law:** The terms and conditions set forth herein, together with any amendments, modifications and any different terms or conditions expressly accepted by Seller in writing, shall constitute the entire Agreement concerning the items sold, and there are no oral or other representations or agreements which pertain thereto. This Agreement shall be governed in all respects by the law of the State of Ohio. No actions arising out of the sale of the items sold hereunder of this Agreement may be brought by either party more than two (2) years after the cause of action accrues.

WARNING

FAILURE OR IMPROPER SELECTION OR IMPROPER USE OF THE PRODUCTS AND/OR SYSTEMS DESCRIBED HEREIN OR RELATED ITEMS CAN CAUSE DEATH, PERSONAL INJURY AND PROPERTY DAMAGE.

This document and other information from Parker Hannifin Corporation, its subsidiaries and authorized distributors provide product and/or system options for further investigation by users having technical expertise. It is important that you analyze all aspects of your application and review the information concerning the product or system in the current product catalog. Due to the variety of operating conditions and applications for these products or systems, the user, through its own analysis and testing, is solely responsible for making the final selection of the products and systems and assuring that all performance, safety and warning requirements of the application are met.

The products described herein, including without limitation, product features, specifications, designs, availability and pricing, are subject to change by Parker Hannifin Corporation and its subsidiaries at any time without notice.

Extensive Automation Solutions

HMI and Controllers



Superior integration and support for machine control as well as HMI hardware and software.

www.parkermotion.com/em/hmicont

Electric Actuators



Screw, belt-driven, and linear motor actuators for the complete range of industrial applications, offering precise motion and flexibility.

www.parkermotion.com/em/linear

Motors and Drives



Parker's family of innovative servo/stepper motors and drives continues to expand to meet the challenges of new technologies.

www.parkermotion.com/em/motordrive

Linear Actuator



Aluminum and steel pneumatic cylinders, guided cylinders, rodless cylinders, and short stroke thrusters from the industry leader.

www.parkermotion.com/pneu/linear

Rotary Actuators



Industry leader in the design and manufacture of pneumatic rack and pinion, and vane-style rotary actuators.

www.parker.com/pneu/rotary

Vacuum Products and Sensors



Vacuum solutions include a broad range of generators (integrated/inline), cups, and pressure sensors.

www.parker.com/pneu/vacsen

Grippers



Parallel, angular, and three jaw grippers are available in over 1,000 configurations.

www.parker.com/pneu/gripper

Airline Accessories



Airline accessories include silencers, flow controls, and mufflers to round out Parker's pneumatic solution.

www.parker.com/pneu/access

Air Control Valves



Valve technology that meets the most demanding requirements in any industrial application.

www.parker.com/pneu/valve

Air Preparation



Parker, the industry leader in air preparation, offers a complete line of products to ensure clean, dry, oil-free air.

www.parker.com/pneu/airprep

Connectors and Tubing



The most complete line of fluid connectors worldwide will meet virtually any automation application.

www.parker.com/pneu/fc

Structural Automation



More than 150 metric and inch profiles, integral motion components, and accessories for unlimited and flexible configurations. Pre-machined kits or complete assemblies.

www.parker.com/ips

EM Sales Offices

Australia

Parker Hannifin (Australia) Pty Ltd.
9 Carrington Road
Castle Hill NSW 2154
Australia
Tel: +61 (0) 2 9634-7777
Fax: +61 (0) 2 9634 3749

Brazil

Parker Hannifin Ind. Com Ltda.
Av. Lucas Nogueira Garcez 2181
Esperança
12325-900 Jacareí, SP
Tel: 12 3954 5100
Fax: 12 3954 5262
Email: automation.brazil@parker.com

Canada

Parker Hannifin (Canada) Inc.
160 Chisholm Dr
Milton, Ontario L9T 3G9
Tel: 905-693-3000
Fax: 905-876-1958
Email: miltoncustservice@parker.com

China

Parker Hannifin Motion & Control
(Shanghai) Co., Ltd
280 Yunqiao Rd. Jin Qiao Export
Processing Zone
Shanghai 201206, China
Tel: (86-21) 50312525
Fax: (86-21) 64459717

France

Parker SSD Parvex
8 avenue du Lac
B.P. 249
F-21007 Dijon Cedex
Tel: +33 (0) 3 80 42 41 40
Fax: +33 (0) 3 80 42 41 23

Germany

Electromechanical Europe
Parker Hannifin GmbH & Co KG
Robert-Bosch-Strasse 22
D-77656 Offenburg
Germany
Tel: +49 (0) 781 509 0
Fax: +49 (0) 781 509 98176

India

Parker Hannifin India Pvt. Ltd
Automation Group-SSD Drives Div.
133 & 151 Developed Plots Estate
Perungudi, Chennai 600 096
Tel: 044-4391-0799
Fax: 044-4391-0700

Italy

Parker Hannifin SpA
Via Gounod 1
20092 Cinsello Balsamo
Milano, Italy
Tel: +39 02 361081
Fax: +39 02 36108400

Korea

Parker Hannifin Korea
9th Floor KAMCO Yangjae Tower
949-3 Dogok 1-dong Gangnam-gu
Seoul 135-860, Korea
Tel: 82-2-559-0454
Fax: 82-2-556-8187

Mexico

Parker Hannifin de Mexico
Eje uno Norte No.100
Parque Industrial Toluca 2000
Toluca, CP 50100 México
Tel: 52-722-275-4200
Fax: 52-722-279-0316

Singapore

Parker Hannifin Singapore Pte Ltd
11, Fourth Chin Bee Road
Singapore 619702
Tel: (65) 6887 6300
Fax: (65) 6265 5125/6261 4929

Taiwan

Parker Hannifin Taiwan Co., Ltd
No. 40, Wuchiuan 3rd Road
Wuku Industrial Park
Taipei County, Taiwan 248
ROC
Tel: 886 2 2298 8987
Fax: 886 2 2298 8982

Thailand

Parker Hannifin (Thailand) Co., Ltd.
1023, 3rd Floor, TPS Building,
Pattanakarn Road,
Suanluang, Bangkok 10250
Thailand
Tel: (66) 02717 8140
Fax: (66) 02717 8148

UK

Parker Hannifin Ltd.
Tachbrook Park Drive
Tachbrook Park
Warwick CV34 6TU
Tel: +44 (0) 1926 317970
Fax: +44 (0) 1926 317980

USA

Parker Hannifin Electromechanical
Automation Division Main Office/
Compumotor/CTC
5500 Business Park Drive
Rohnert Park, CA 94928 USA
Tel: 707-584-7558
800-358-9070
Fax: 707-584-8015
Email: emn_support@parker.com

Parker Hannifin Electromechanical
Automation Division/Daedal
1140 Sandy Hill Road
Irwin, PA 15642
Tel: 724-861-8200
800-245-6903
Fax: 724-861-3330
Email: ddllcat@parker.com

